

TC 5-340

**AIR BASE DAMAGE REPAIR
(PAVEMENT REPAIR)**

HEADQUARTERS, DEPARTMENT OF THE ARMY

DISTRIBUTION RESTRICTION: Approved for public release; distribution is unlimited.

AIR BASE DAMAGE REPAIR (PAVEMENT REPAIR)

TABLE OF CONTENTS

	PAGE
PREFACE	ii
CHAPTER 1: CONCEPT OF THE OPERATION	1-1
CHAPTER 2: AIR BASE EMERGENCY OPERATIONS	2-1
CHAPTER 3: ARMY AND AIR FORCE INTERFACE	3-1
CHAPTER 4: PREATTACK ACTIONS	4-1
CHAPTER 5: POSTATTACK ACTIONS	5-1
CHAPTER 6: PAVEMENT REPAIR CRITERIA	6-1
CHAPTER 7: STRUCTURE AND UTILITY REPAIR CRITERIA	7-1
Appendix A: Air Force Crater Repair	A-1
Appendix B: Army Crater Repair	B-1
Appendix C: Army and Air Force Spall Repair	C-1
Appendix D: Assembly and Fabrication of Polyurethane Impregnated Fiberglass Mats and AM-2 Matting	D-1
Appendix E: Unexploded Ordnance and Explosive Ordnance Disposal	E-1
Appendix F: Army Facilities Components System	F-1
Appendix G: Air Force Engineering Organizations	G-1
Appendix H: Typical Crew and Equipment Configurations	H-1
GLOSSARY	GLOSSARY-1
REFERENCES	REFERENCES-1
INDEX	INDEX-1

PREFACE

This training circular provides doctrine to commanders and staffs concerning the repair of damaged air bases. It provides a single source of information on all aspects of air base damage repair (ADR). The circular describes the ADR environment, Army and Air Force interaction during peacetime and war, and the potential missions for Army engineer units.

Air base damage repair can be defined as the responsive restoration of air bases to operational levels after an attack. Restoration of air bases after an enemy attack is critical to provide vital tactical air and logistical support in both developed and undeveloped theaters of operations. Tactical air support is an essential combat multiplier that must be available for victory. Since air power is dependent upon support bases to launch and recover aircraft, air base survivability is essential. Efficient and responsive restoration of damaged air bases will be a critical factor in determining the outcome of any conflict.

Air base damage repair includes repair of pavements, structures, utilities and essential support facilities that are required for aircraft launching, recovery, rearming, refueling and security. This training circular addresses AirLand battle (ALB) doctrine; nuclear, biological, and chemical (NBC) operations; and Threat analysis. Also discussed are ADR responsibilities and criteria which have led to the repair methods currently used by Army and Air Force units to repair craters and spalls and to remove unexploded ordnance (UXO). It provides a practical approach for repairing air base pavements and discusses the materials, equipment, and techniques used by the two services.

Approved for public release; distribution is unlimited.

Unless otherwise stated, whenever the masculine or feminine gender is used, both men and women are included.

CHAPTER 1

CONCEPT OF THE OPERATION

Success on the AirLand battlefield depends on securing and retaining the initiative and exercising it aggressively. Key to obtaining the initiative is achieving air superiority or at least air parity. This requires significant offensive and defensive air capability which is dependent on fixed ground bases. These air bases must be protected by air and ground defenses, if they are to survive, and they must quickly become operational following enemy attacks. Hence, quick and efficient repair of damaged air bases will be critical in any theater of operations. Operations may be conducted in mature, forward-deployed theaters or immature, contingency theaters. This may occur during prehostility actions as well as during actual hostilities. In either case, air power will be essential.

TACTICAL AIR OPERATIONS

The first consideration in employing air forces is gaining and maintaining freedom of action to conduct operations against the enemy. Control of the air gives commanders the freedom to conduct successful attacks which can neutralize or destroy an enemy's warfighting potential. This campaign for control of the air is a continuous attempt to gain and maintain the capability to perform combat missions and to deny the enemy the use of friendly airspace. Control of the air enables land forces to carry out a plan of action without interference from enemy air forces. Without this control, tactical flexibility is lost.

Launch and recovery of aircraft from functional air bases are key to gaining and maintaining air superiority. For this reason, air base survivability has become a cornerstone of the ALB doctrine, and ADR will be critical to success in any future conflict.

HISTORICAL PERSPECTIVE

The need to provide aircraft an acceptable takeoff and landing platform was recognized during World War I (WWI). There was little damage to the air bases then, and the majority of the problems was the result of returning friendly aircraft attempting to land. Damage to these first air bases was minor and could be easily repaired by a few soldiers using handtools. As aircraft became faster and runways more sophisticated and significantly longer, the potential for major repair grew. Airfields became air bases as more support facilities were required. For the first time, support facilities took on an importance almost as great as the aircraft. Enemy capability to cause damage also increased.

Between the World Wars, airplane weights quickly exceeded the bearing capacity of the natural earth surfaces used in WWI. Prior to the outbreak of World War II (WWII), the need to establish an ADR capability was recognized by the US, but no units existed to satisfy this requirement. An event that caused the US to more closely examine the need for this type of capability was

the German invasion of Poland. This included massive air attacks that were extremely successful. The US Army organized the 21st Engineer (Aviation) Regiment which was composed of small groups of skilled construction and engineering troops who were trained with air units. It was envisioned that this unit would repair damaged air bases, construct camouflage, and provide base defense if needed. These aviation engineers were not expected to do heavy construction, and in peacetime would have no mission at all.

Following the Japanese attack on Pearl Harbor, concern for repairing air bases continued to increase. Fortunately, many of the soldiers available to perform this work required little training, as many of them had previous construction experience in civilian life. By 1942, the importance of air power and the inherent need for rapid air base construction and repair was recognized. Adequate civilian labor forces that possessed engineer skills were no longer available and a shortage developed. Manpower was not unlimited and obtaining adequately skilled personnel became more difficult as the war progressed.

When the Air Force became a separate service, the question was raised concerning command and control of aviation engineer units. The solution adopted was for the Army to organize and train the force while the Air Force would maintain operational control.

During the Korean Conflict, aviation engineers were organized into an engineer command assigned directly to the numbered air force. The command and control issue between the Army and Air Force continued until 1955 when operational control was returned to the Army.

During the Vietnam War, the Air Force perceived the need for an air base contingency engineering capability of its own. To satisfy this need, the Air Force created specialized civil engineering squadrons (discussed in Appendix G) that were extensively used throughout the Far East. Army and Air Force engineers worked together in several air base construction efforts. For example, Phan Rang Air Base in Vietnam was constructed primarily by Army engineers with the assistance of Air Force units. Damage repair during the Vietnam War was also a joint effort, although this was minor.

This is the situation today. The Army and Air Force each has engineering forces that can be made available to undertake ADR missions. In addition, there are host nation military and civilian engineer assets that may be used to support ADR missions.

THE THREAT

Realizing the importance of air power to the US operations, Threat doctrine has placed a high priority on the destruction of our air bases. The enemy may employ three modes of attack to accomplish this objective.

- Air-Delivered Munitions, Air forces can expect to be outnumbered in most potential theaters and most overseas main operating bases (MOB), collocated operating bases (COB), and aerial ports of debarkation (APOD) are within range of existing Threat tactical air capabilities. Attacks on air bases may involve the use of up to 20 different munitions ranging from strafing rounds to 1,000 kilogram bombs. Addi-

tionally, UXO is anticipated, both timed and pressure-sensitive devices. All repair activities will be greatly complicated by the fact that Threat forces may also use persistent chemical or biological agents.

- **Missile-Delivered Munitions.** Threat forces can be expected to employ land-based missiles to deliver highly explosive, chemical, biological, or time-delay (blast) munitions. Over 3,000 such weapons are deployed in the European theater and are expected to augment Threat air strikes, especially during night or adverse weather conditions. Tactical missiles may also be available to Threat forces in other theaters of operations.
- **Special Operations Ground Forces.** Threat forces can be expected to use this mode of attack in either a low or high intensity conflict. Because of the small nature of these tactical forces, their objectives will be to destroy off-base utility systems (water, electrical, petroleum, oils, and lubricants (POL), or roadway) and harass or destroy base resources using long range weapons. Defense from this Threat is complicated by the dispersal of vulnerable utilities, inherent lack of cover on the air bases, the extensive base perimeter, and the skill and weaponry of the Threat force.

Base support is a high priority mission for many Army air defense units, and wartime plans call for their support of the theater air bases. The US fighter aircraft will also be used in an air defense role. In spite of these efforts, damage is expected and ADR will be essential to ensure the “air” stays in the AirLand battle.

MISSION OVERVIEW

The purpose of this section is to define Army and Air Force responsibilities for ADR and to describe the nature of the ADR mission. Although the specifics will vary with each air base and wartime scenario, the Army engineer mission may consist of the following four phases:

- Deployment.
- Preattack Support.
- Postattack Support.
- Air base Restoration.

Army engineer units may or may not provide preattack support depending upon theater priorities for engineer support. Repair responsibilities will be defined first, and then the mission phases will be discussed.

REPAIR RESPONSIBILITIES

The Air Force is primarily responsible for the emergency repair of the air base. This includes the

emergency repair of the air base paved surfaces, which is called rapid runway repair (RRR). This is accomplished through the employment of Air Force base civil engineering troop assets; Prime BEEF (Base Engineer Emergency Forces) and RED HORSE (Rapid Engineering Deployable Heavy Operational Repair Squadrons, Engineering) units. The Army is responsible for semi-permanent construction, the beyond emergency repair of the air base and, upon request, emergency repairs which exceed the Air Force's capability. Joint service regulation AR 415-30/AFR 93-10 specifies these repair responsibilities for each service.

Army Responsibilities for ADR

The Army provides engineer support to the Air Force overseas. It ensures that units are equipped, manned, and trained to support Air Force needs. This support includes--

- Assisting in emergency repair of war-damaged air bases where requirements exceed the Air Force's organic repair capability.
- Repairing and restoring damaged air bases beyond emergency repair.
- Assisting in force beddown (provision of expedient facilities to meet the wartime needs of in-place and deploying forces) that exceeds Air Force's organic capability.
- Developing engineering designs, plans, and materials to meet Air Force needs as agreed upon by the Air Force. Where practicable, designs will be based on the Army Facilities Component System (AFCS).
- Supplying construction materials and equipment, except for that provided by the Air Force.
- Upon request, assist within their capabilities in the removal of UXO declared safe by explosive ordnance disposal (EOD) personnel and limited damage assessment operations.
- Managing and supervising the repair and restoration of war damage performed by Army personnel. The Air Force base commander sets the priorities for air base repair.

Air Force Responsibilities for ADR

The Air Force provides military troop engineering support from its resources. The Air Force ensures that units are equipped, manned, and trained adequately to support its needs. This support includes--

- Emergency repair of war damage to air bases.
- Force beddown of units and weapon systems, excluding Army base development responsibilities.
- Operation and maintenance of facilities and installations.

- Crash rescue and fire suppression.
- Managing force beddown and the emergency repair of war damage.
- Supplying materiel and equipment to perform its engineering mission.
- Providing logistical support to the Army for ail classes of supply except II, V, VII, and IX.
- Conducting damage assessment and removal of UXO.
- Providing NBC collective shelters and establishing and operating personnel and equipment decontamination sites for the air base and the Army. There are shortages of these assets on air bases and support to army units may be limited.

Air base support agreements may be established in some theaters between the Air Force and the host nation where ADR support capability exists. These host nation support agreements may include equipment, materials, and manpower assets.

DEPLOYMENT PHASE

The objective of the deployment phase is for the engineer unit to obtain a mission-ready status at its air base location. This objective typically consists of the following procedures:

- Mobilization. The engineer unit must travel to its mission site. Multiple trips for disabled equipment and likely congestion on main roadways will complicate this step of the deployment phase.
- Bivouac. This step includes all aspects of establishing shelter and survivability near the air base. This location should have been thoroughly reconned prior to mobilization and must provide adequate disperement for both personnel and equipment. The site must be capable of defense against a dismounted Threat force and should be within the range of pre-positioned, close air defense weapons.

The unit must be prepared to conduct combat operations for defense against rear area threats. The rear area threat may range from terrorist activity to raids, ambushes, and reconnaissance operations conducted by combat units to heliborne, airborne, or infiltration operations. The role of engineers in Direct Support (DS) of an air base should exclude association in base security. The prevention of being overrun by a battalion-size or larger enemy ground force and participation in area damage control outside base perimeter is the exception.

Since air bases are fixed facilities, the doctrinal practice of avoiding contaminated areas is critical within the limits of the air base perimeter.

The engineer unit will attain its mission-ready status only after integration with the Air Force command and control and communication structures. This step includes the following actions:

- Standardization of command procedures.
- Coordination of logistical support.
- Integration of engineer representative into the Damage Control Center (DCC).
- Coordination with other adjacent units.

PREATTACK PHASE

The objective of the preattack phase is to minimize the vulnerability of the air base. To achieve this, engineer assets perform three types of missions as directed by the Base Civil Engineer (BCE)--

- Dispersal and Stockpile Operations. All repair materials need to be consolidated in convenient locations to satisfy projected repair requirements. Damageable items are dispersed and provided cover and/or concealment.
- Hardening. Critical base facilities are hardened to mitigate the effects of a Threat attack. This typically requires earth berms, revetments, or sandbags to strengthen existing structures. The mission includes supporting the air defense artillery (ADA) units deployed in the air base area.
- Deception. The Air Force will employ deception to waste enemy munitions on non-targets. Examples are false runways and "dummy" airplanes. Critical facilities and targets may be made to appear destroyed (with strategically placed rubble and painting) or at least camouflaged.

Attacks on air bases will not usually come as a complete surprise. The distance between our MOB and Threat air facilities should be sufficient to provide warning to base personnel. While not the preferred Threat method of assault, missile attacks provide little or no notice. The presence of enemy ground forces should be made known through intelligence channels, although small-scale harassing attacks may occur without notice. Again, trends in the use of this mode of attack will develop early in the conflict and be available through intelligence channels.

During an actual attack, the primary objective of the engineer unit will be survivability. Depending on the unit's posture at the time of attack, it may augment base security forces against a battalion-size or larger ground threat. Base defense during an attack does not require major support from the engineer unit and, therefore, does not constitute a phase in the ADR mission. Preattack actions are described in detail in Chapter 4.

POSTATTACK PHASE

The immediate objective of all base personnel, once an attack has ended, is still that of survivability. It must be assumed that NBC agents have been employed and, until proven otherwise, personnel and equipment must be protected.

Survivability assured, Air Force personnel initiate damage assessment. This survey of base facilities (to include structures, utilities, and paved areas) will provide the BCE and wing commander the information needed to determine the total extent of damage. This information, along with the tactical air unit's requirements, is evaluated by the base commander who will determine the base's operational requirements. These requirements typically address the Minimum Operating Strip (MOS), quality of repair, and support facilities required to satisfy his tactical mission. These operational requirements provide the BCE a framework to determine repair priorities.

A thorough damage assessment is critical to ensuring that repair efforts are not wasted. It is possible that the base commander may declare the air base nonrepairable and direct the relocation of the unit. In this worst case situation, only those repairs required to launch grounded aircraft one time would be executed.

The damage assessment mission will be greatly hindered by possible enemy use of the NBC agents and presence of UXO. Each air base is assigned civil engineers and ordnance experts to conduct this mission. Because assessment and UXO are such major factors in the ADR mission, the Army engineer unit should be prepared to assist in its accomplishment. This assistance should always be done under the direct guidance of Air Force ordnance experts.

Having cleared UXO and been assigned repair priorities, RRR and other emergency repair efforts will commence. Although RRR and establishment of an MOS normally have priority, emergency repair of minimum essential facilities may also be conducted at the same time. Although an Air Force mission, Army assets may be used to support these immediate repairs. The Army engineer unit's priority missions normally will be those requiring semi-permanent repairs or beyond emergency repair. They will be executed under the direction and control of the engineer unit commander. Beyond emergency repair of the paved surfaces, structures, and facilities is the primary responsibility of the Army and normally commences 12 to 20 hours after emergency repair. Postattack actions are described in more detail in Chapter 5.

Some of the factors discussed during the deployment phase must also be taken into consideration during the postattack phase--

- Cover and concealment.
- Camouflage.
- NBC contamination avoidance, decontamination, and protection.
- Security.
- Air defense.
- Host nation support.

There continues to be a rear area threat and a high probability of follow-on or repeated attacks.

Throughout this portion of the ADR mission, there will be three major organizations performing repair tasks--

- Air Force "Prime BEEF" Teams. The Prime BEEF units consist of about 200 military personnel permanently assigned to an MOB. These units will normally be augmented early in the war by an additional 200-airmen mobile Prime BEEF unit to provide a second shift capability. These airmen work for the BCE and are well trained in all the technical skills required for the operation and repair of the air base.
- Air Force "RED HORSE" Units. All RED HORSE units are of a 400-airmen engineer unit. The RED HORSE concept evolved from the Air Force's need for a responsive, heavy repair and expedient construction force. The RED HORSE units will primarily be deployed to locations with large beddown requirements.
- Army Engineer Units. Army engineer units may have been assigned the high priority mission of supporting ADR operations for the Air Force. Functionally, the units provide DS to the air base civil engineer and serve alongside RED HORSE squadrons and the Prime BEEF teams.

AIR BASE RESTORATION PHASE

Having restored the air base to an operational condition, the engineer unit will likely revert back to preattack missions in preparation for repeated attacks. As the battle progresses, the effectiveness of enemy air forces is expected to diminish as our air defense and reinforcement forces take their toll. Missile and ground force threats will continue to be a concern, but the Army engineer units may be tasked to provide support to other rear area facilities.

The mission of restoring air bases to operational capability after an enemy attack is just one demand of Army engineer units. The engineer commands will have many demands put upon it and will respond in accordance with the theater priorities.

CHAPTER 2

AIR BASE EMERGENCY OPERATIONS

The Air Force in the Theater of Operations operates from four different types of air bases. These are MOB, APOD, COB, bare base and forward operating locations (FOL). The MOBs are those bases that have Air Force units stationed during peacetime. In austere environments the Air Force will also operate from bare bases and FOL. The primary role of US Forces (Air Force and Army) will be on MOBs, whereas APODs are those bases scheduled to receive, via airlift, reinforcement units from the US during wartime. The COBs are installations to be employed as war-fighting locations for US reinforcing units, and are generally the responsibility of the host nation. United States engineers may, however, share wartime damage repair responsibility. The two types of Air Force engineering units that will be involved with ADR are the RED HORSE and Prime BEEF. These units are discussed in detail in Appendix G.

AIR BASE COMMAND AND CONTROL

The air base command and control organizational structure is depicted in Figure 2-1. The responsibilities of the different organizations are briefly summarized.

FIGURE 2-1. AIR BASE COMMAND AND CONTROL ORGANIZATIONAL STRUCTURE

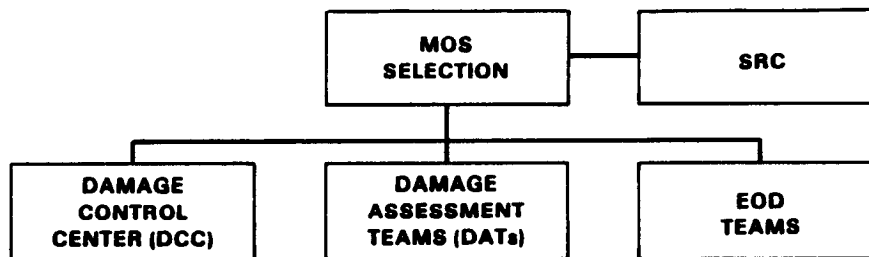

Survival Recovery Center (SRC)

Each air base establishes an SRC that is responsible for coordinating all base recovery and base support activities. It is manned by the air base commander, the Combat Support Group (CSG) commander, and a recovery staff comprised of representatives from essential organizations. These include EOD, Disaster Preparedness, and Civil Engineering, and are required to restore and provide base support functions. Civil engineering functions performed in the SRC include directing damage assessment operations, recording and evaluating damage reports, plotting damage locations on air base drainage maps, accomplishing MOS selection, developing repair plans and bills of materials (BOM), and directing recovery operations.

During RRR operations, the SRC directs the damage assessment effort, receives the reports, plots damage and UXO data, and makes an MOS selection. The SRC then directs the Damage Assessment Team (DAT) to initially mark the selected MOS, orders EOD forces to begin UXO safing operations, and instructs the Damage Control Center (DCC) to begin repair operations.

Damage Assessment Team

The DAT receives direction from the SRC, reports damage and UXO data, and initially marks the selected MOS. In addition, the DAT may assist the RRR OIC in identifying damage to be repaired and checking the quality of repairs.

MOS Selection Team

The MOS selection team, located in the SRC, plots damage and UXO data received from the DAT and, after MOS selection is complete, the team continues to monitor and record damage repair and EOD progress.

Damage Control Center

The DCC is manned by the BCE, key BCE supervisory personnel, including the OIC for runway repair operations. The DCC monitors and plots all incoming damage and UXO data reported by the DAT. After the MOS has been selected, the SRC designates the location of the MOS and identifies the location of craters to be repaired. The SRC specifies the quality of repairs and designates which taxiways and access routes are to be cleared and repaired. If the damage is slight and effective control can be maintained, the OIC may elect to remain in the DCC. In most cases, the OIC will proceed to the runway area, join the arriving repair forces, and assume control at the site. The OIC directs crews to craters, designates haul routes to be cleared, and determines which stockpiles are to be used. The OIC also commits any additional resources which have been held in reserve. The OIC must identify delays or difficulties in the early stages of an arising problem in order to take corrective action promptly. This assures the unimpeded progress of the recovery effort.

The Army engineer unit will receive its missions from the DCC. Hence, a better tracking of ongoing projects can be relayed. The engineer unit establishes liaison with the DCC and permanently stations a radio with operator there. Currently, the Air Force does not have radios capable of communicating with the Army.

The DCC consists of senior representatives from various civil engineering areas. They are Pavement and Grounds, Structures, Mechanical, Electrical, Power Production, Sanitation and Fire Protection. These are described in Table 2-1.

The special teams formed in a contingency situation are the DCC, Damage Assessment, MOS selection, RRR, and Facility Damage Assessment. Within the structure of the Damage Assessment and MOS selection are the EOD personnel. The make-up of the special teams varies from theater to theater but should be manned and equipped as indicated in Table 2-2.

TABLE 2-1. THEATER WAR DAMAGE REPAIR FORCE TEAMS

Team	Responsibilities
Survival Recovery Center	Provides information and advice to wing/base command staff on base recovery activities. Provides command and control for BCE operations.
MOS Selection	Evaluates and plots information received from DATs and, based on this information, will recommend MOS candidates and connecting taxiways.
Damage Control	Provides organization and direction for all BCE recovery operations, provides central point for damage inputs and direction of BCE response, operates the BCE communications network to coordinate BCE recovery operations.
Facility Damage Assessment	Surveys damaged facilities and utilities, evaluates repair and demolition requirement, estimates manpower and equipment requirement.
RRR Damage Assessment	Surveys damaged air bases and facilities, evaluates repair and demolition requirements, classifies, records, and marks UXO locations, determines or marks routes of travel for repair. (Assists UXO teams for air base battle damage where UXOs may exist. The base recovery after attack (BRAAT) concept of operations suggests this specialized RRR assessment team be formed.)
Pavements and Grounds	Responsible for rescue assistance, wrecking, demolition, excavation, debris clearing and removal, pavement repair, gross area decontamination, including entomological prevention.

TABLE 2-1. THEATER WAR DAMAGE REPAIR FORCE TEAMS (CONTINUED)

Team	Responsibilities
Structures	Responsible for rescue assistance, wrecking, shoring, repair and restoration of damaged facilities, and construction of temporary facilities.
Mechanical	Responsible for restoration or expedient re-establishment of essential utilities to critical base facilities. (Some staff may have to be reserved for full time operation of essential services and be excluded from repair teams.)
Electrical	Responsible for restoration or expedient re-establishment of electrical power to critical base facilities.
Fire Department	Responsible for minimizing loss of life and property. Prevent damage which seriously degrades mission capability. Use Appendix 4, Fire Protection, of Annex S, USAF War and Mobilization Plan Vol I (WMP-1), to determine required staffing. (The number shown is an example only. See referenced document for further guidance.)

TABLE 2-2. CONUS CONTINGENCY RESPONSE FORCE TEAM

Team	Responsibilities
Crisis Action	Similar to wartime SRC. Provides command and control for DCC during actual emergencies and exercises.
Damage Control Center	Organizes and directs all BCE recovery operations, provides central point for damage inputs and directs response,

TABLE 2-2. CONUS CONTINGENCY RESPONSE FORCE TEAM (CONTINUED)

Team	Responsibilities
	operates the CE communications network to coordinate recovery operations.
Damage Assessment	Surveys damaged facilities and utilities, 8 evaluates repair or demolition requirement. The actual repair team coordinates on-scene recovery operations in conjunction with the BCE DCC Team.
Pavement and Grounds	Responsible for rescue, wrecking, demolition, excavation, debris clearing and removal, pavement repair, and gross area decontamination.
Structure	Responsible for rescue, wrecking, shoring, repair and restoration of damaged facilities, and construction of temporary facilities.
Mechanical	Responsible for restoration or expedient re-establishment of essential utilities to critical base facilities.
Electrical	Responsible for restoration or expedient re-establishment of electrical power to critical base facilities.
Sanitation (490)	Responsible for repair, restoration or expedient re-establishment of water and waste systems, entomological prevention control of insects, rodents, pests and vegetation.
Fire Department	Responsible for aircraft crash rescue, EOD assistance, gross area decontamination, search, rescue, and structural fire fighting.

CHAPTER 3

ARMY AND AIR FORCE INTERFACE

The scope and priority of the ADR mission may require Army and Air Force engineer units to operate jointly as a skilled and responsive team. Although each service will maintain its own command and control functions, an understanding of the assets, capabilities, and operating procedures of each is essential. In planning for war and executing plans in war, the engineer commander needs to understand what the supported unit needs. The best way to solve this problem is to understand pre- and post-conflict planning doctrine.

The Air Force will depend on currently employed engineering personnel (military, US civilian, and host nation local hire) in the forward-deployed theater of operations until active duty and Air Reserve Force (ARF) Prime BEEF and RED HORSE personnel arrive in theater. The expected initial shortfall of Air Force engineering personnel and equipment creates a vital role for the deployed Army engineer units in the early days of conflict. These units may be required to augment the BCE staff for other than war damage repairs.

Contingency operations could require Army engineer units to construct an air base or extend an inadequate existing facility. These same units may remain on site to assist the BCE until adequate Air Force personnel and equipment are available to conduct engineering repair and maintenance functions. The nature of the conflict could necessitate Army engineer units remaining on site to conduct war damage repairs.

Regardless of the theater, the Army and Air Force interface must be effective and efficient. Attainment and sustainment of air superiority is a critical facet of success in combat. Army engineers play a key role in this and both services must ensure that coordination at the working level is on-going. Army and Air Force engineer personnel must work toward a single goal-generation of air sorties.

COMMAND AND CONTROL OF ENGINEER SUPPORT

Army engineer units working on an air base will normally be in DS of the BCE. In a DS role, a unit is commanded and task organized by the parent unit but must respond to support requests from and the work priority established by the supported unit. The DS unit must maintain liaison and communication with both the parent and supported unit. Although the parent unit normally provides logistical support to the unit in DS, this is not the case when conducting ADR. Some logistical support will be provided by the air base to the supporting Army engineer unit. The air base should normally provide all classes of supply except II, V, VII, and IX.

The Air Force manager of ADR is the SRC as described in Chapter 2. The SRC functions similar to the Army Rear Area Operations Center (RAOC) and coordinates closely with the Engineer Command (ENCOM). Each numbered Air Force establishes an Engineering and Service Readiness Center (ESRC). The ESRC is responsible for coordinating activities at its subordinate air bases which include beddown, air base damage reporting, project review, and resource allocation decisions. The engineer brigades are in general support of the numbered Air Forces and maintain close liaison with any ESRCs that are located in their areas of operation. The engineer groups in turn maintain close liaison with the BCEs of any air bases in their areas of operation.

EMERGENCY REPAIR SUPPORT

Air base requests for emergency repair support go directly to the engineer group, who responds in accordance with the theater construction priorities. In some instances, Army engineer units may be employed on air bases performing preattack missions. In these cases, they respond directly to the BCE in supporting air base recovery operations. Air base commanders not satisfied with the engineer group response elevate the issue to the numbered Air Force ESRC for coordination with the engineer brigade. The relationship between the Air Force and the ENCOM is shown in Figure 3-1.

FIGURE 3-1. AIR FORCE/ENCOM RELATIONSHIPS

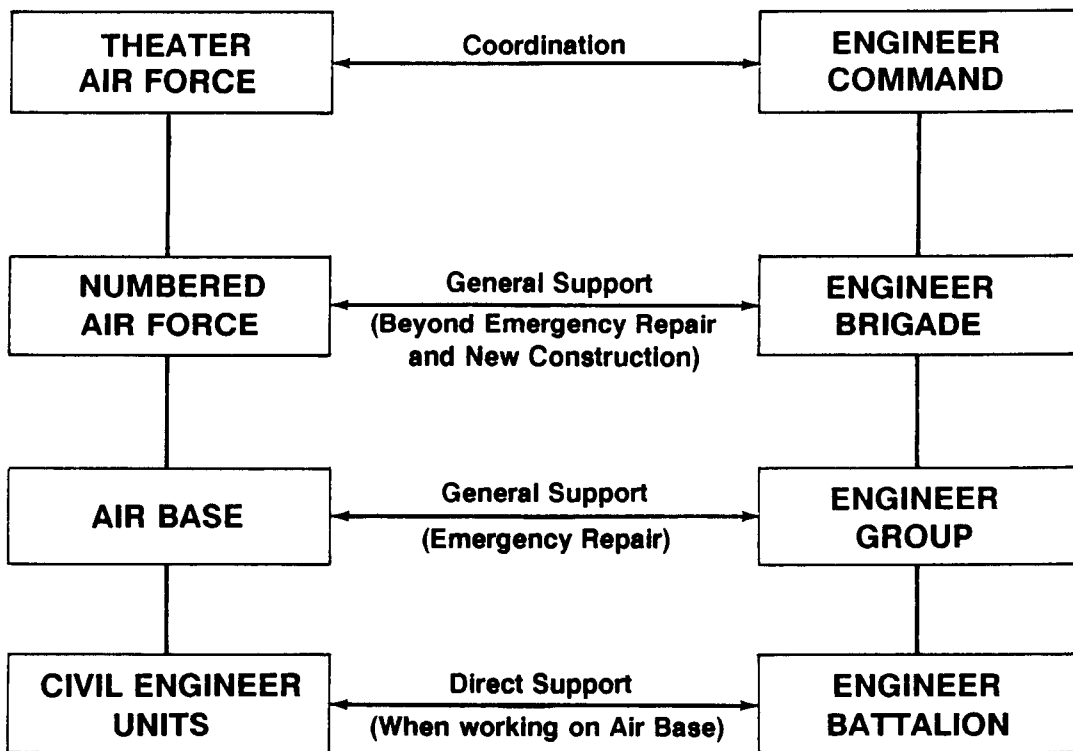

BEYOND EMERGENCY REPAIR SUPPORT

Air Force requests for engineer support beyond emergency repair and new construction are prioritized by the numbered Air Force and forwarded to the engineer brigade for integration into its backlog of outstanding construction projects. Projects are prioritized in accordance with the overall theater priorities and passed to the engineer group for execution. The engineer group will determine how long an engineer battalion or company remains working on an air base, but the BCE will determine what projects are to be worked on as long as the engineer unit remains on the air base.

EQUIPMENT AND MATERIALS

The Air Force transportation unit maintains a prescribed load list (PLL) similar to the Army. In this listing will be bench stocks of parts for low density engineer equipment such as bucket loaders and dump trucks. While not all equipment is similar in design, the supporting unit should be aware of similar equipment and have a copy of the PLL listing. The Army and Air Force should mutually exchange their listings to facilitate emergency repairs. The BCE will have a listing of all vehicles available for recovery operations.

In peacetime, the Air Force BCEs stock repair materials. These should be exhausted first, if emergency repairs are needed, regardless of which component is doing repairs. Also, mature theater air bases are fixed and have established local procurement channels that may be used as a source of repair materials for both components. Reimbursement may still be required.

To illustrate what the engineer battalion can expect from the air base elements, refer to Figure 3-2. This will enable the engineer commander to understand what support and information can be obtained from base operations, base defense, and the BCE. It also shows that the engineer unit at the air base may be required to submit situation reports to the next higher command element.

FIGURE 3-2. ENGINEER UNIT RELATIONSHIP WITH AIR BASE STAFF ELEMENTS

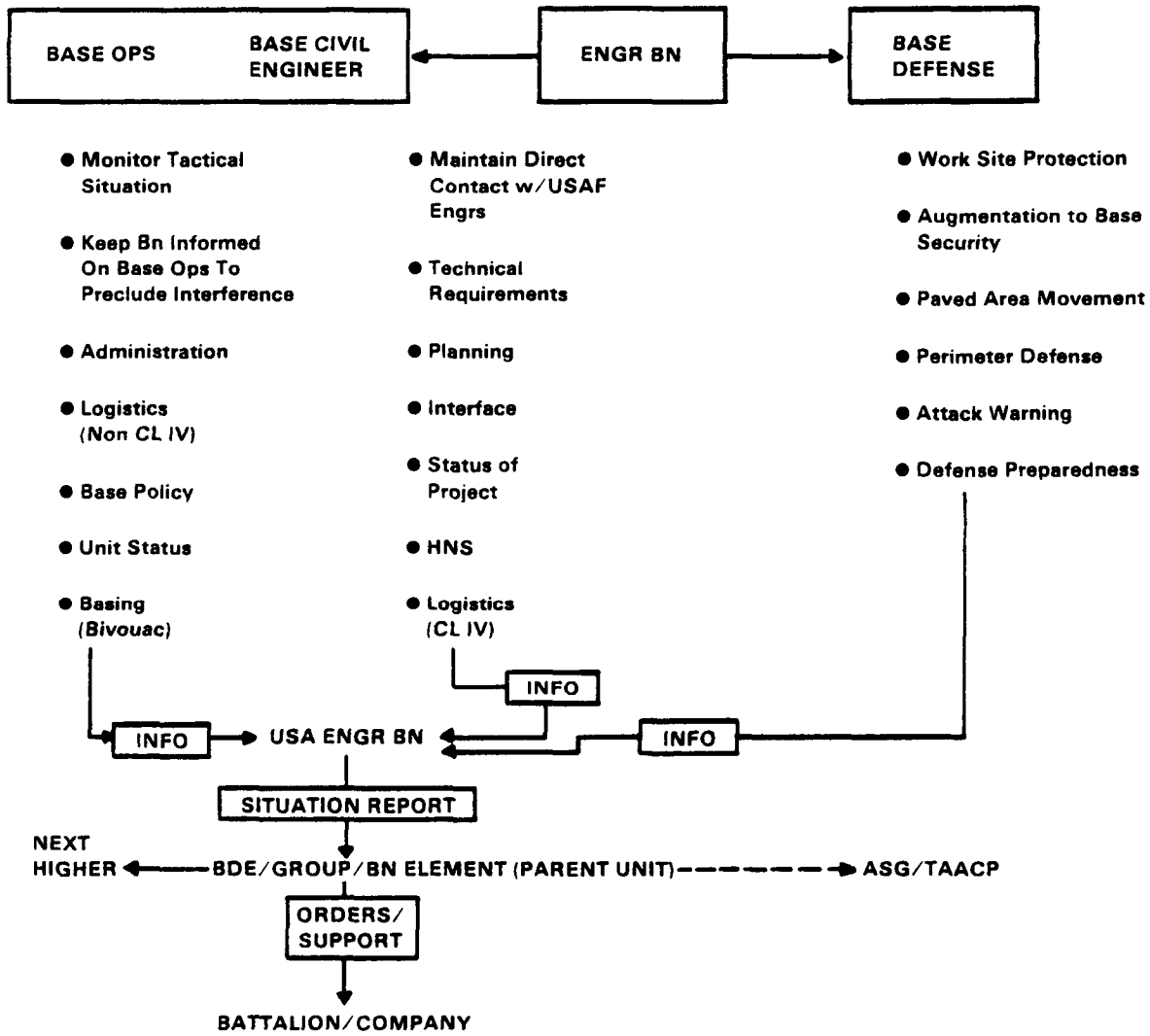

CHAPTER 4

PREATTACK ACTIONS

An air base is a stationary and permanent facility that is easy to identify and target. With this in mind, air base preattack planning is extremely extensive. The air base commander will develop a base recovery plan and task organize the resources to respond to an attack. Supplies and equipment will be staged to expedite postattack repair.

Prior to the attack, Army engineer units may be moved to air bases as contingency measures. As discussed in Chapter 1, preattack activities center on the engineer unit's survivability and the establishment of command, control, and communications. The air base will be taking preattack measures to increase the survivability of the air base facilities, structures, aircraft, and personnel. Because of a shortage of air base personnel to accomplish all preattack missions, Army engineers may be tasked to support these or other related activities. When Army engineers are used to assist in the Air Force preattack effort, all materials, special tools and equipment, kits, and designs will be provided by the air base. Army personnel must also have their Military-Oriented Protective Posture (MOPP) gear in order to cope with potential NBC attack.

The Air Force will be primarily involved with resource protection procedures. Resource protection may be divided into two categories, personnel protection and facility, and equipment and material protection. The basic concepts for protection of resources at MOBS include deception, dispersal, hardening, obstacles, and redundancy.

DECEPTION

Deception is a measure designed to mislead enemy forces by manipulation, distortion, or falsification of evidence to induce them to react in a manner prejudicial to their interests. A Threat evaluation and a vulnerability assessment of the air base is made to determine effective measures of physical deception. Intelligence estimates of enemy capabilities in terms of aircraft, avionics, armament, and target acquisition aids are used to determine the threat to an installation. Camouflage, both natural and artificial, are used to conceal or disguise targets, especially high risk target areas. Air Force camouflage techniques and materials are similar to those used by the Army such as the use of decoys and camouflage nets. Army engineers may be requested to assist the deception effort.

DISPERSAL

Dispersal is the relocation of forces for the purpose of increasing survivability. Dispersal plans, developed during peacetime, are reviewed by the BCE before the attack to determine how they

apply to the current situation. The greater the warning time, the more attractive dispersal becomes. The perceived impact of the Threat is also a consideration. Dispersing resources requires manpower and equipment assets for transportation. Dispersal activities include identifying dispersal locations, assets, and methods; loading trucks with equipment and materials; organizing convoys and land movements to sites offbase; arranging airlift support for long-range dispersal; and changing dispersal routes as needed to reflect the current situation. Army engineers may be requested to assist in this transportation-intensive task.

HARDENING

Hardening, in general terms, includes all physical measures employed to prevent or reduce the loss of critical resources due to the destructive effects of conventional weapons systems. Hardening measures may be long term, such as a reinforced concrete structure, or expedient, such as a rapidly constructed sandbag structure. The base commander is responsible for the selection of the facilities and equipment that will be hardened, and the BCE is responsible for ensuring that the hardening process is accomplished. Normally, items which are most essential to continuing the base mission will receive priority for protection. Aircraft, command and control centers, personnel shelters, and communications centers are typical high priority facilities which are good candidates for hardening. The primary hardening methods that can be employed without extensive reconstruction effort are sandbags and revetments. Sandbags are normally considered an expedient method of hardening existing facilities and their effectiveness depends on the type of fill material. Revetments are used to protect parked aircraft and essential facilities from the effects of enemy ordnance. The types of revetments to be constructed will depend upon the target to be protected, layout of aircraft parking areas, materials available, and the enemy capability to directly fire on the area. If an Army engineer unit is asked to assist in hardening facilities, materials, kits, special equipment and tools, and designs will be provided by the BCE organization.

OBSTACLES

Obstacles are installed to stop, delay, or divert enemy movement. Army engineers should be familiar with the types and construction of antipersonnel and antivehicular obstacles such as concertina wire and may provide materials and request engineer units to construct obstacles on or around the air base.

REDUNDANCY

Redundancy is the concept of providing an excessive amount of resources to accomplish the mission. In most cases it is unlikely that Army engineers will become involved with any redundancy operations except possibly redundancy in air base surfaces. This is the concept of providing alternate launch or recovery surfaces. For example, sections of existing highway systems in various theaters could be pressed into service as emergency air bases. Army engineers could assist with the necessary conversion of such areas designated for this purpose.

CHAPTER 5

POSTATTACK ACTIONS

A significant portion of on-site equipment and personnel could be lost during the initial attack. The postattack environment, complete with NBC and UXO, may increase the number of casualties. In addition, degradation caused by extended MOPP wear will occur as a result of CB attacks. The initial attack could also render air base utilities, such as water, power, and fuel supply ineffective. It has been projected that up to 25 percent of the paved surface of an air base could sustain damage requiring repair.

Figure 5-1 Illustrates a hypothetical runway and taxiway area that has sustained a large number of hits from bombs. Not shown are the numerous small craters that would result from smaller munitions. The circles are scaled to represent large craters and to provide an overall impression of possible damage. The structurally damaged zone can extend through the pavement into the subgrade. The exact shapes of the craters are dependent upon such factors as the type and size of explosive, depth of penetration, pavement type and thickness, and subgrade soil type. Figure 5-1 gives a perspective view of hypothetical damage at runway-ramp intersection. This view illustrates that intersection closure can be achieved with one properly placed hit. Closure can be further enhanced with scatterable mines and UXO.

FIGURE 5-1. HYPOTHETICAL AIR BASE DAMAGE

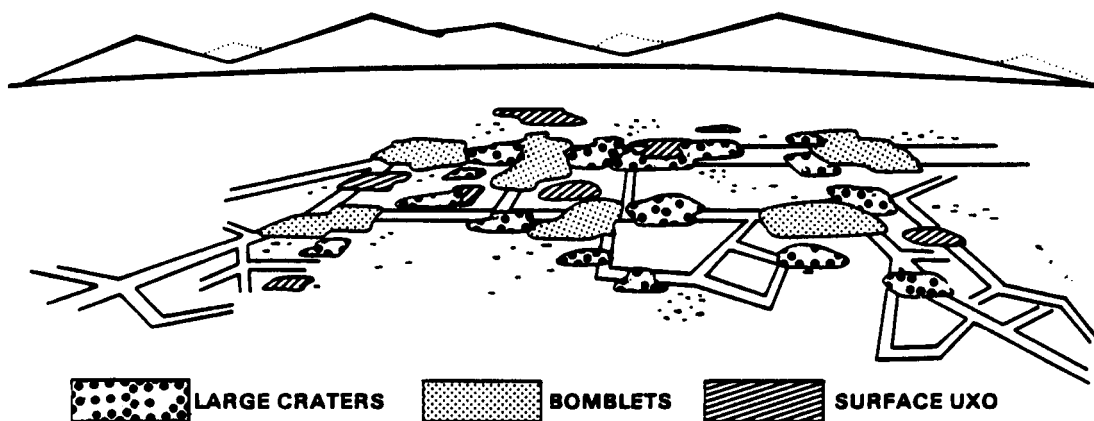
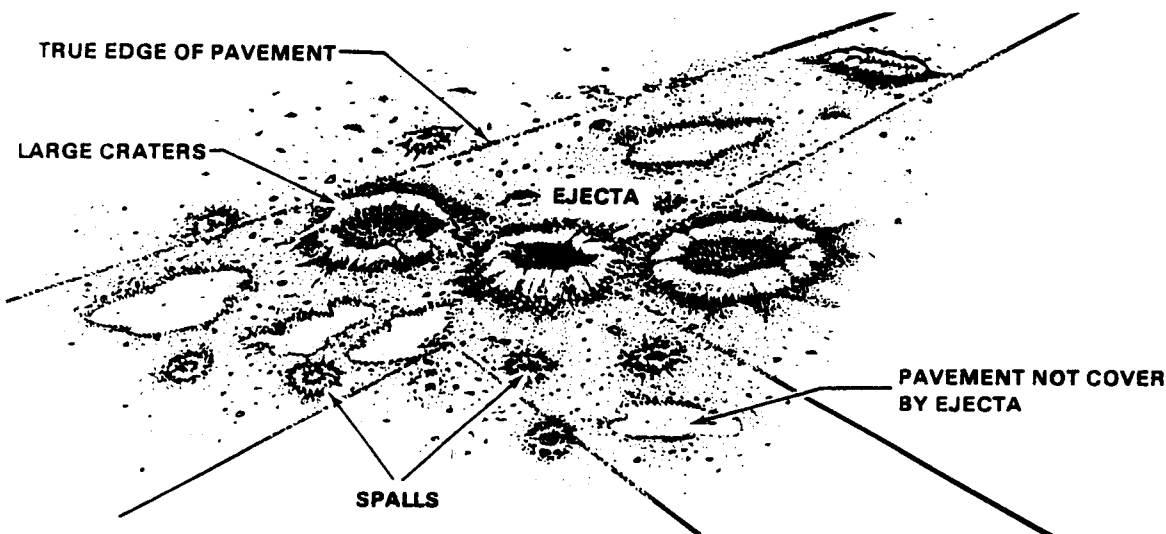

Figure 5-2 illustrates the cumulative effect of several large bombs and small munitions and shows that ejects can cover all but a small portion of the entire paved surface. The ejects layer, found in the crater and on the surrounding surface area, exists in considerable quantity. The probable volume of ejects commensurate with this damage could be up to 6,000 cubic yards, or an average of up to 8 inches in depth over a 5,000-foot section of the runway or taxiway area. Since many of the craters can be expected to have a depth in excess of the thickness of the pavement structure, the ejects will consist of all materials from the pavement down to and including the subgrade material. Therefore, ejects can consist of clay, sand, gravel, and asphalt and concrete fragments in a wide range of sizes up to and including concrete slabs. While much of the ejects will be used to backfill the craters, extensive sweeping is required to clear the runway of the remaining ejecta.

FIGURE 5-2. HYPOTHETICAL DAMAGE AT RUNWAY INTERSECTION



DAMAGE ASSESSMENT

Before any repairs can be accomplished following a hostile attack, it is essential that an effective damage assessment operation be completed. Air Force engineering repair teams must know what areas are damaged, the extent of the damage in each area, and approximately what will be required to repair the damage. A rough initial estimate of damage can be obtained by observations from good vantage points around the base. This includes control towers and reports by flight line observation posts, security police, and other organizations. If available, helicopters might be used to conduct aerial reconnaissance and damage assessment. A more detailed assessment of damage requires dispersal of teams to evaluate specific destruction.

Damage assessment activities may be separated into two distinct areas, runway damage assessment and facility damage assessment, also called main base damage assessment. Runway

damage assessment involves the assessment of damage to runway surfaces, taxiway surfaces, and any other collateral damage encountered. Main base or facility damage assessment includes assessment of damage to all air base facilities and utilities. Resources permitting, both operations should be conducted simultaneously and depending on the situation, may be of equal importance. Because of the importance of restoring the air base runway to operational use following an attack and the complexity of RRR damage assessment, this will be discussed first.

RUNWAY DAMAGE ASSESSMENT

Runway damage assessment is the vital first step toward restoring an operational runway after an enemy attack. During damage assessment, the locations, types, quantity of UXO, and air base pavement damage are determined and reported to the Civil Engineering DCC. This information is relayed to the base commander in the SRC. A qualified team in the SRC uses this information to select the minimum airfield operating surface (MAOS) that must be cleared and repaired to restore the operational capability of the air base. The MAOS consists of MOS and its supporting taxiways or access routes. Since major recovery tasks cannot be started until damage assessment and MAOS selection are completed, speed and accuracy during damage assessment are essential.

To shorten air base restoration time, the damage assessment operations and the EOD/UXO assessment operations will be done jointly. Thus, the DATs are organized to conduct ground assessments of UXO locations and bomb damage either on foot or from vehicles.

TEAM COMPOSITION AND LEADERSHIP

The DATs normally consist of one EOD technician, one civil engineering specialist, and one or more augmenters to aid the assessment, record information, and communicate data to the SRC. The teams work together to locate and identify UXO and pavement damage. The EOD expertise is necessary to accurately identify and classify UXO and oversee the activities of the DAT in the hazardous UXO environment. The civil engineering DAT member determines the location and size of craters, span fields, and other runway damage. The ranking member of the team will normally be the team leader. However, regardless of rank, the EOD technician takes charge and directs the team's movement through areas with UXO.

DAMAGE ASSESSMENT DATA

During damage assessment, the DATs gather two types of information-- location of pavement damage caused by bombs, cannon fire and so forth, and locations of UXOs. The UXO that may influence aircraft operations must be accurately located, reported, and recorded in sufficient detail for the SRC/EOD representative to determine the risk to aircraft operations. The following information is included in the report:

- Location.
- Quantity.

- Size.
- Shape.
- Color.
- Distinctive markings.
- Fuze type and condition.

All UXOs within 300 feet of repair operations or aircraft operating surfaces must be identified. Holes of entry for subsurface UXO and camouflaged craters must also be reported. Thus, scaled drawings must show sufficient adjacent area to include the 300-foot, UXO radius-of-effect zone for paved surfaces and crater mat assembly areas.

Pavement damage to potential MOS surfaces will also be recorded on the same scaled drawings as the UXO reports. The following information is included in each report:

- Damage type (crater, single spall, span field, and so forth).
- Location (by grid coordinates or in relation to known reference markers).
- Size (crater diameter, spall field dimensions).
- Number (of spalls in a field).

ASSESSMENT TECHNIQUES

Current recovery planning is based on a two-phase damage assessment activity--initial reconnaissance and detailed damage assessment. In Phase I, an initial gross assessment is made of the air base damage to quickly locate areas of UXOs and pavement damage. The results of the preliminary survey helps the SRC to quickly direct the assessment teams to those areas requiring detailed damage assessment. In detailed damage assessment (Phase II), the DATs follow an SRC-directed travel route from their staging location to their area of responsibility. Under the direction of the SRC, the teams report the level of damage along these travel routes. Detailed damage assessment requires more accurate locating of damage than the initial reconnaissance because these reports are the basis for MOS selection.

Initial Reconnaissance (Phase I)

The purpose of Phase I, initial reconnaissance, is to quickly assess the postattack environment to identify the areas of pavement damage. Precise damage locations or measurements are not expected because most of the Phase I observations are made at some distance from the damaged area. The initial reconnaissance should be made from preselected observation posts by personnel trained in damage and pattern recognition. Examples of observation posts are the control tower, air base point defense positions, aircraft shelters, or other specific points that provide air base vantage points. When hostilities are imminent, personnel will be assigned to all

unmanned observation posts. After the attack, these individuals make visual observations and report the size and location of all damage as quickly and accurately as possible. Reporting procedures will depend on preattack instructions and available communications. Some observers may report directly to the SRC while others report to their organizational control center.

For the UXOs threatening the launch and recovery surfaces, the individuals should attempt to report size, location, color, condition, and so forth of the UXOs. Also, the extent of undamaged pavement areas or any recommendations for MOS placement should be reported. From these observations, potential MOSs may be selected, based on damage patterns. If the damage is too extensive or uniform to allow MOS selection, the SRC will direct DATs to assigned areas to conduct detailed damage assessment.

Detailed Reconnaissance (Phase II)

Phase II damage assessment will be extremely hazardous and may be time consuming, depending on the level of damage. Since the extent of damage is unknown, several DATs (usually up to three teams) are designated prior to an attack and dispersed to protected locations on the base. Following an attack, dispersal is important to ensure these personnel are available to conduct the vital first step in establishing an operational air base runway. Immediately after an attack, the SRC relays damage assessment instructions to each team. This message is normally transmitted by radio and will include initial reconnaissance information, assigned damage assessment routes, and any special instructions necessary to define the task at hand.

The success of the damage assessment operation depends on dedicated communication links and strict communication procedures to ensure accurate transmission of damage information. The current concept calls for separate EOD and civil engineer radio nets for transmission of this information. The EOD and engineer representative on each team will transmit UXO and damage information to the SRC. With several teams, as well as other personnel around the base passing information to the SRC over these radio nets, the potential for confusion is great. Clear, concise radio transmissions using strict radio discipline are essential.

Detailed reconnaissance may be conducted using possible damage assessment techniques, manual or vehicular:

- **Manual Damage Assessment System (MDAS).** Under the MDAS, the runway or taxiway surface is surveyed by DATs on foot. Team members walk specified areas of the runway, identifying and locating UXO and damage. If possible, measurements are made by pacing distances from known runway or taxiway locations, by estimating crater dimensions, and by visually determining UXO identifying features. Although the MDAS is the most accurate damage assessment method, it is extremely time consuming and exposes team members to UXO fragmentation and blast hazards.
- **Vehicle Damage Assessment System (VDAS).** Where the MDAS is a slow and hazardous damage assessment method, the VDAS offers increased speed and protection to the team. With the VDAS, an armored vehicle is used to transport the team between UXO and crater locations while providing protection from UXO blast and

fragmentation effects. These benefits are not provided without some cost to system effectiveness. Visibility from inside the vehicle is restricted by the armor protection. This means the team must locate and identify UXO and damage from greater distances using binoculars. This limitation contributes to errors in reporting the size, position, and identification of UXO or damage. The accuracy of this method will vary from person to person based on distance, weather conditions, time of observation (night or day) and other human factors, such as fatigue and fear. The best travel route will be along the pavement centerline. This route gives equal visibility and allows team personnel to visually sweep the runway with binoculars forward and to the sides of the vehicle. Obviously, a meandering path may have to be taken to avoid large UXO or pavement damage. When this is necessary, the DAT must be careful not to miss damage or UXO on the side of the runway. Because the vehicle is used for protection, the damage assessors should remain in the vehicle except for extreme cases where this would hamper the assessment effort. An example would be a scenario where the extreme level of damage has destroyed the reference system. In this case, the assessors would have to measure the distance from the nearest remaining reference marker to assure the required accuracy.

Damage Recording and Reporting

Once the damage is assessed, it must be recorded and immediately reported to the SRC for damage plotting and MOS selection. The speed of reporting depends on the complete understanding of the information being relayed and strict adherence to radio discipline by SRC and damage assessment personnel. A list of the reported damage should be kept by the assessment team for verification purposes when the DAT returns to the SRC.

Priorities

The SRC directs each assessment team to its area of responsibility based on the initial reconnaissance reports. In general, the areas to be assessed in order of importance are the takeoff and landing surfaces; access routes; maintenance, reloading, refueling areas; and other areas as directed by the SRC (Figure 5-3). In these areas, all craters, spalls, and UXOs must be reported.

FACILITY DAMAGE ASSESSMENT

The concepts and principles used to conduct RRR damage assessment also apply to facility damage assessment. The specialty make-up of the base DATs will depend upon the type of facilities to be investigated, as well as the number of qualified personnel available. Also, the presence of UXO and chemical agents may require EOD and disaster preparedness personnel participation. Manning will probably be limited during a contingency response, so the minimum number of persons necessary to evaluate damage will be assigned. An example DAT formed to assess damage to buildings on the base may consist of an officer, a carpenter, an electrician, and a plumber. The team proceeds to evaluate damage areas, makes repair estimates, and assists in the coordination of recovery efforts.

FIGURE 5-3. CRITICAL AREAS TO BE SURVEYED

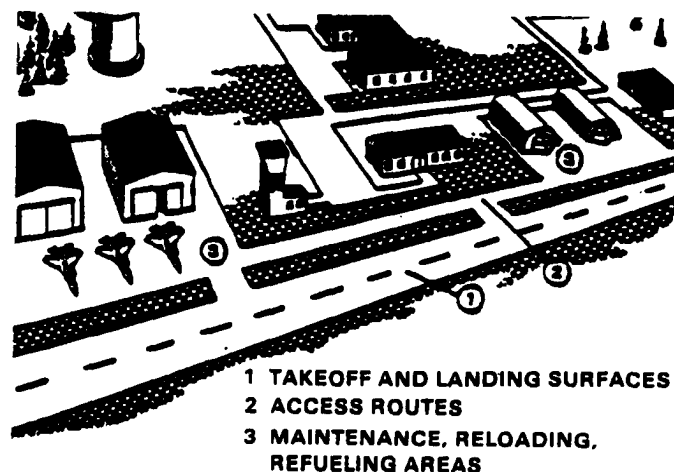

Damage Evaluation

The team inspects the highest priority areas first. Following a bomb attack, structures may be weakened, live electrical lines may be down, and gas lines may have ruptured releasing explosive vapors. These potentially hazardous conditions require that the DAT be very careful in its initial evaluation. In many cases the team will be the first persons venturing into an area following an attack. Consequently, the team must ensure that the area is safe before beginning assessment activities. For example, if a building looks unsound, the team should not enter to make more specific observations until a determination is made that the structure will not collapse. Broken electrical wires present another hazard that should be avoided by team members. Potentially life-threatening situations are reported immediately so crews can be dispatched to isolate the danger.

The DAT's next responsibility is to determine the feasibility of repairing a facility. Those facilities which are beyond repair should be considered for demolition. If the structure or utility does not present an immediate danger, it can be left for destruction at a later time. Those which endanger human life should be earmarked for immediate demolition.

As the DAT conducts its evaluation, damage should be immediately reported by radio so that repair teams may be dispatched. The DAT also records the extent of damage and marks the damage locations on reference maps. This provides a degree of redundancy in the recording system should additional information be required at a later time.

Emergency Repair Estimates

A very important task of the DAT is the repair estimate. Repair estimates should include required labor, materials, and equipment. The accuracy of these estimates will be crucial if the DCC is to do its best in allocating limited civil engineering resources.

Coordination of Recovery Efforts

Although the DCC team is responsible for the management of the recovery effort, the DAT can provide useful coordination of on-scene recovery operations. Since the team has first-hand knowledge of the damage, it can provide important suggestions to the DCC regarding the employment of repair crews. At the direction of the DCC, the team may be required to coordinate the efforts of repair crews in the damage area.

CHAPTER 6

PAVEMENT REPAIR CRITERIA

Damage assessment provides information concerning the location and extent of damage of the paved surfaces and facilities of the air base. The base operations center provides information on operational requirements and expected operating conditions following the attack. Using this information, the SRC designates the location of the MOS to be repaired and designates the required quality of repairs. After approval by the base commander, EOD teams go to work on the designated area to clear UXO. Finally, the RRR teams perform emergency repairs by repairing craters and spans, clearing debris, repairing collateral damage, and marking the MOS location.

SELECTION OF THE MOS

The MOS is the smallest section of the runway required for launching and recovering an aircraft. Based upon the damage assessment after an attack of the air base, it is possible to select a section of runway which requires the least apparent amount of time and effort to repair. BCE may recommend the location of the MOS to the SRC but the SRC will determine its final location. Currently, the minimum dimension of the MOS for fighter aircraft is 50 feet wide by 5,000 feet long, as required by the Air Force. However, present trends in research and development may expand the dimension to 75 feet wide by 5,000 feet long. For cargo aircraft, specifically a C141B and aircraft of the Civil Reserve Air Fleet (CRAF), the MOS must be at least 90 feet wide by 7,000 feet long.

There are three methods in use, or under development, for making the MOS selection. Basically, the methods range from totally manual to fully automated. Advancements in technology have provided for the future fielding of a computerized system, often referred to as the Damage Information Reporting System (DIRS), which may greatly reduce the time required to determine the optimal location of the MOS.

An MOS may be located on the main runway, on a parallel taxiway, or even on an alternate launch and recovery surface on or off base. The MOS location affects launch or recovery status by restricting the flight approach of aircraft or by limiting air traffic control and access.

ACCESS ROUTES

In order to get aircraft to and from an MOS, access routes are required. Access routes from aircraft shelters or parking areas to the MOS must be restored and maintained to a minimum width of 25 feet for fighter aircraft. The access route must be a smooth surface free of debris.

An AM-2 landing mat, M-19 mat, and fiberglass matting are excellent expedients which can serve to maintain and repair access routes. Access routes must be widened to 60 feet when the air base is upgraded to accept large cargo aircraft.

SURFACE ROUGHNESS CRITERIA

The BCE must also determine the surface roughness criteria for the selected MOS. The surface roughness criteria refers to the relative smoothness of the runway surface. In basic terms, surface roughness refers to three major factors. They consist of maximum slope of upheaval from the original pavement surface, maximum height of upheaval above the original pavement surface, and maximum sag along the repaired surface of the crater (see Figure 6-1). The maximum acceptable surface roughness values vary considerably from aircraft to aircraft. Additionally, the frequency and severity of damage in a given MOS affects the maximum acceptable surface roughness. For example, tolerances are greater for a single crater within an MOS than for two successive craters.

FIGURE 6-1. SURFACE ROUGHNESS MEASUREMENT

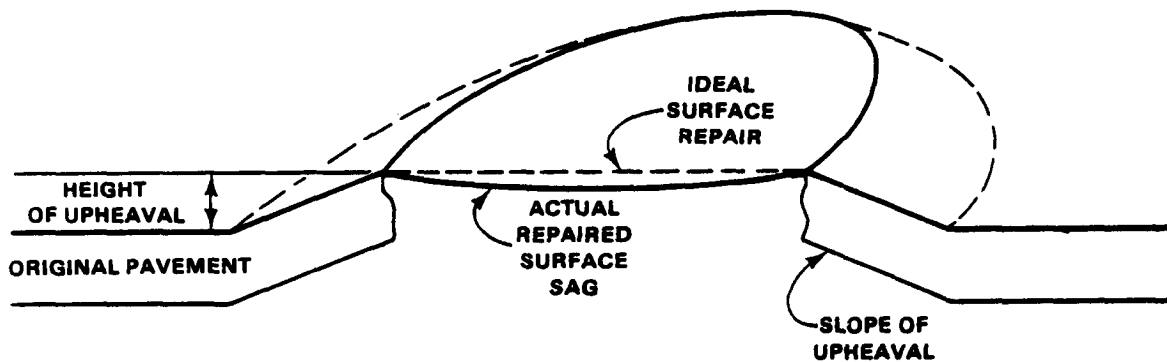

UXO REMOVAL

The UXO may include--

- Bombs and warheads.
- Guided and ballistic missiles.
- Artillery, mortar, and rocket ammunition.
- Antipersonnel and land mines.
- Demolition charges.
- Pyrotechnics, grenades and all similar or related items or components explosive in nature, designed to cause damage to personnel or material.

The Threat is likely to use scatterable mines and time-delay fuzes to attack an air base, to supplement numerous bombs and cannon fire, and to prevent rapid repair. In addition to these "intentional" munitions, the air base is likely to be covered with ordnances of all sizes which mal-

functioned and did not explode as designed. Many of these "unintentional" munitions explode later and act as unpredictable, time-delay munitions. Any UXO will be effective in rendering initial repair efforts especially hazardous. Not only can UXO damage equipment, but experienced equipment operators may be injured and other operators will be more cautious and fearful, causing reduced efficiency.

There is likely to be a large quantity of UXO covering the runway after an attack. The UXO will vary in size as well as type and will significantly hinder pavement repair operations if left in place. To successfully accomplish the ADR mission, UXO must be removed from the runway and access routes.

Joint service regulation AR 415-30/AFR 93-10 specifies that the Air Force will perform UXO clearance following an attack. To accomplish this mission, the Air Force has trained EOD personnel who support the various air bases. Air Force doctrine supports the joint service regulation by stating that all UXO will be cleared by Air Force EOD personnel.

Army engineers should be prepared to assist in any phase of the EOD procedures. These phases include the identification, reporting, marking, demolition, and/or recovery and disposal of UXO. Army engineers should not handle any UXO until it has been rendered safe by EOD personnel, unless the Army and Air Force commanders jointly agree and authorize otherwise. The type of ordnance, availability of EOD personnel, mission requirements, and time constraints are all factors which will be considered before Army personnel are further committed to the explosive ordnance effort.

The MOS has priority for clearance of UXO and the current methods used for removal of UXO are discussed in Appendix E. There are a number of considerations concerning UXO that need to be mentioned.

Army engineers must be cautious when beginning work in a previously unrepaired area. A UXO may be buried beneath the ejects covering the MOS or may be buried in the crater itself.

One other aspect of UXO which must be considered is that of a munition, such as a concrete penetrator, which has penetrated the runway and has lodged in the subbase or subgrade without exploding. The location of such unexploded concrete penetrators cannot be detected by any equipment presently in the field. The point of entry is the only evidence of the existence of the UXO. Studies indicate that a concrete penetrator is most likely located within a 50-foot radius of the entry hole. Accordingly, selection of an initial MOS should not include such areas. In the absence of a BCE, the Army engineer must keep this in mind. In any event, equipment and personnel are kept clear of such an entry point until the munition explodes and a normal repair method can be performed.

REPAIR OF BOMB DAMAGE

The Threat has many capabilities for causing severe damage to an air base. The use of numerous types of conventional bombs and cannon fire are the most likely. These weapons cause craters and spans of varying shapes and sizes (see Figure 6-2).

FIGURE 6-2. DIRECT DAMAGE CROSS SECTION

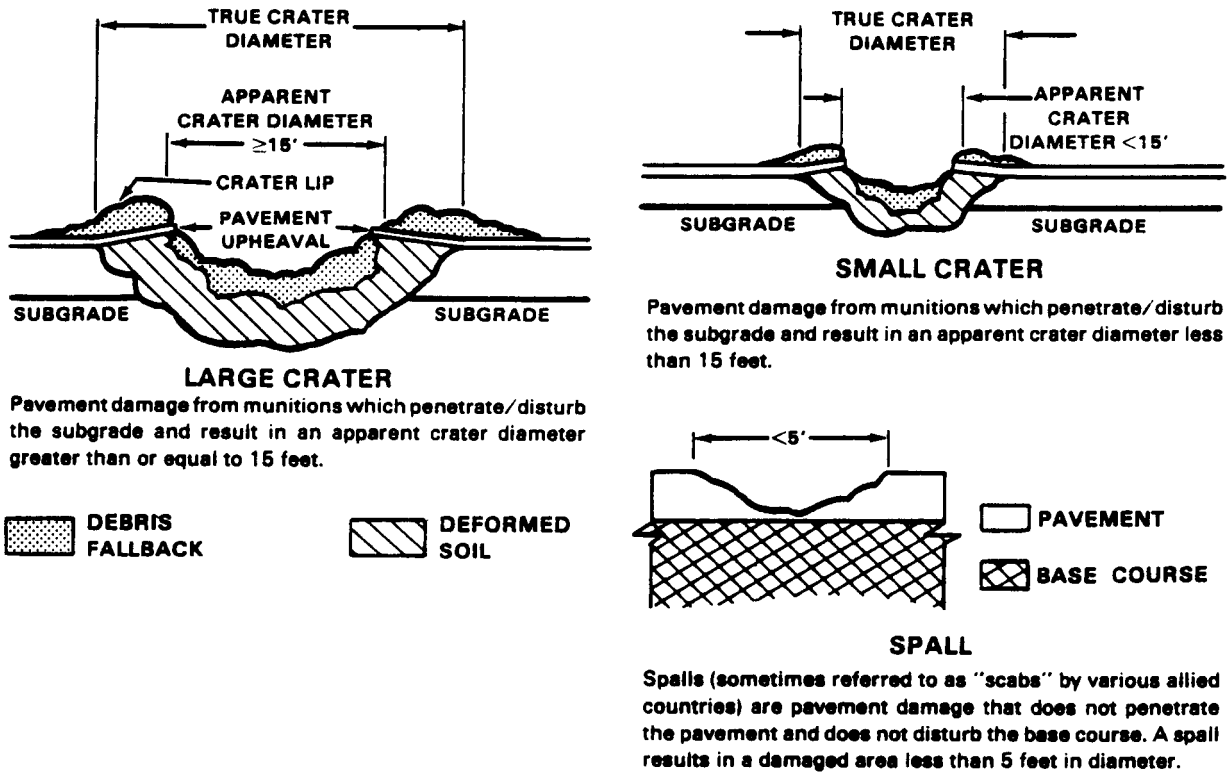

There will also be extensive damage to the structures and utilities on the air base. For instance, allied air bases in Europe may suffer greater than 40 percent damage to facilities. Some of the facilities are essential to the functioning and operation of the air base. These structures and utilities are required for launching, recovering, rearming, refueling, and securing the aircraft.

Emergency Repair

After selection of the MOS and removal of UXO, debris can be removed and craters and spans can be repaired. If repairs need to be made to create an MOS, these repairs must be completed within the first four hours after an enemy attack. Repair to provide such an expedient capability is called "emergency" repair. Emergency repair criteria is expected to withstand 1,000 sorties (one takeoff and one landing by one aircraft) of an F4 (or 500 sorties by an F15) and 50 sorties of a C141B. The methods and materials used by Army and Air Force for emergency repair of craters and span repair are discussed in detail in Appendices A, B, C, D, and H. While the MOS is being repaired during those first four hours, fighter aircraft will use alternate launch and recovery sites.

Beyond Emergency Repair

Repair efforts designed to upgrade emergency repairs for increased aircraft traffic are known as "beyond emergency" repairs. While it is not known how long emergency repairs will last due to

the volume of the aircraft traffic, it is recommended that Army units begin beyond emergency repairs not later than 12 to 20 hours after emergency repairs are completed. Beyond emergency repair is expected to withstand unlimited sorties of fighter aircraft and 2,200 sorties of a C141B. "Expected to withstand..." means that these numbers of sorties can be made before additional maintenance is required. While speed is important for conducting beyond emergency repairs, quality control is even more important so that further maintenance will be minimized. Once the conflict is over, permanent repairs will return the air base to its original condition. The methods and materials used for beyond emergency repair of the pavements are discussed in detail in Appendices B and H.

There are several factors which should be considered when repairing the runway, taxiway, and parking apron--

- Foreign object damage (FOD) is the damage to aircraft by debris either hitting the aircraft (breaking lights or causing dents) or entering turbines and damaging the engines. Debris removal or sweeping the air traffic areas of all rocks and dirt will help minimize this type of damage.
- Generally, the greater the surface roughness allowed for a given crater, the less time required for the repair effort. Decreasing the amount of surface roughness allowed (up to the point of repairing the surface to its original grade specifications) increases the amount of time required for repair. Therefore, if time is critical, use the maximum allowable roughness to make the quickest repairs. Army engineers must understand that in the absence of an acceptable surface roughness criteria provided by an Air Force BCE (for example, at a forward Army airfield), the runway should be repaired as closely as possible to its original grade. In spite of the additional time this repair method requires, it ensures the operational capability of the air base.

PRIORITY OF WORK FOR SURFACES

The priority of work will be dependent upon a number of factors. The amount of damage, availability of repair materials, time, troops, and equipment will all impact on this. On an Air Force base, the air base commander will determine the priority of work. On Army or host nation air bases, the Army repair force commander may be the one to set priorities. Whatever the case the first priority is emergency repair and the establishment of an MOS. Minimal effort is expended to provide access routes for aircraft to travel to the MOS, along with any structures and utilities that require immediate attention. After the completion of emergency repairs, a list of priorities may include--

- Commencement of beyond emergency repair.
- Construction of a second, separate, and distinct MOS (see Figure 6-3)
- The repair of more than one MOS is desirable. During subsequent attacks, the enemy will find it more difficult to identify and disable multiple MOSS. Multiple MOSS allow the temporary closure of one of the MOSS for maintenance and

upgrade beyond emergency repair. This will also allow the retrieval of emergency repair materials for conducting emergency repair in the event of follow-on attacks.

- Additional 25-foot-wide access routes are completed to allow greater access to more shelters and base facilities.
- The first MOS is lengthened to 7,000 feet to improve operational safety since adverse weather (rain) increases the takeoff and landing distances required by fighter aircraft.
- Repair and upgrade of structures and utilities.

FIGURE 6-3. MULTIPLE MOS CONCEPT

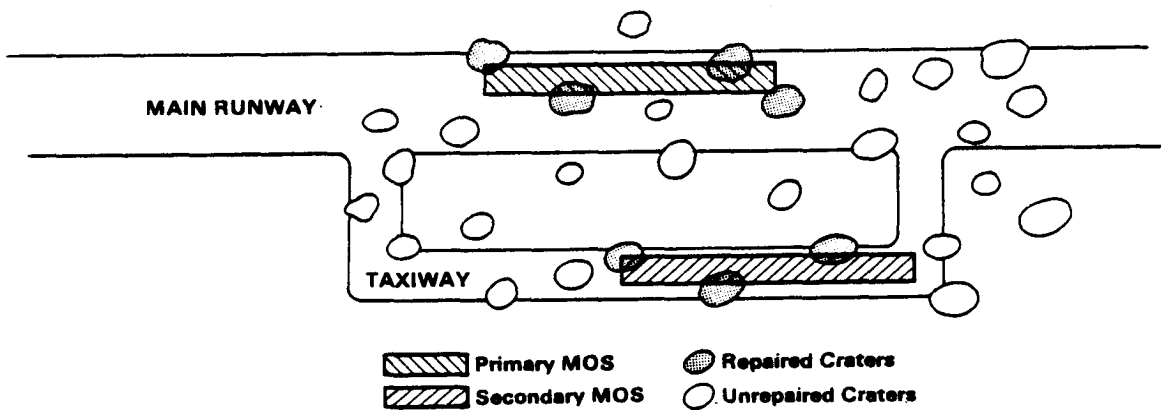

CHAPTER 7

STRUCTURE AND UTILITY REPAIR CRITERIA

Facility damage assessment provides information concerning the damage to the structures and utilities on the air base. In addition to repairs to the pavements, repairs to the structures and the utilities are necessary to return the air base to an operational status. Again, the Air Force is responsible for expedient or emergency repairs to these facilities. Army engineers should assist in the effort when it exceeds the organic capabilities of the Air Force engineering forces. The Army is responsible for repair and restoration of facilities beyond the immediate emergency recovery requirements of the air base.

REPAIR RESPONSIBILITIES

Normally, repairs to facilities will be made using materials similar to those of the original construction. For severely damaged facilities, restoration may require reconstruction. In all cases, there should be maximum use of available host nation resources.

When conducting these repairs, the BCE should furnish the following to the Army engineers:

- Aircraft or missile physical characteristics.
- Allowance factors.
- Formulas and broad design.
- Layout and design criteria.
- Policy guidance through definitive drawings, outline specifications, regulations, Air Force organizational tables, manuals, or other references that are peculiar to Air Force construction.
- Technical and advisory personnel, as required.

Army engineers ensure that all of their construction plans and specifications are technically adequate and have Air Force concurrence. When practicable, designs should be based on the AFCS which is discussed in Appendix F.

Army organization for structure and utility repair is discussed in Appendix H.

The air base may maintain user adequacy surveillance (observe, examine, or inquire into their projects) but will not duplicate the Army unit's day-to-day supervision, inspection, and quality

control. The air base representative will formally accept the completed project with drawings and related items that identify and describe the constructed facilities (as-built drawings).

PRIORITY OF REPAIR FOR STRUCTURES AND UTILITIES

Generally, damage repair to the runway and taxiway system is the first priority mission. After pavement repair, the following activities are considered for repair efforts in the listed priority:

- **Navigational Aids (NAVAIDS)/Runway Lighting.** The NAVAIDS and runway lighting are vital to the operation of aircraft in continuing the base mission. Engineering efforts at these facilities will consist of repairs to electrical power systems, mechanical repairs, and structural repairs.
- **Command Post/Command and Control Facilities.** The various command and control facilities coordinate air base flying and non-flying activities and are essential for effective operations following a hostile attack. Engineering support will consist of structural and utility repairs, as well as continued expedient maintenance to ensure that these critical facilities remain in operation.
- **Communications Facilities.** Reliable communications are required for coordination of rescue and recovery efforts and for the effective management of combat resources after an enemy attack. In either case, the engineer function will be to provide utility and structural repairs to communications facilities and any assistance that might be required from the communications repair crews.
- **POL/Munitions Facilities.** Adequate supplies of POL for both aircraft and ground vehicles will be required during an emergency. Repairs to these facilities will be performed by the Air Force civil engineering force. Repair of munitions facilities will be critical following an enemy attack to support future combat operations.
- **Fire Station.** Following an enemy attack, there are likely to be conditions which will contribute to the start and spread of fires. Additionally, during any emergency there will be requirements for the specialized rescue skills of fire department personnel. Since the fire station must continue to function to manage these diverse activities, restoration of structural integrity and basic utilities will be essential.
- **Medical Facilities.** The numerous injuries that will occur during an enemy attack require that medical facilities receive a high priority in contingency repairs.
- **Flexibility in Priority Assignment.** The priorities stated here should not be considered fixed. They will be established by the air base commander based on the situation and his mission.

STRUCTURES AND UTILITIES TO BE REPAIRED

Army engineer units that conduct ADR may be required to assist Air Force personnel in the emergency repair effort or be tasked to conduct beyond emergency repair of the structures and

utilities. it is therefore important that Army engineers, as a minimum, are familiar with certain air base systems.

AIR BASE MARKING

Air base marking is the identification of the usable runway surface and should be accomplished in the shortest possible time after an attack. Marking procedures include obliteration of conflicting, existing markings, and the painting of new markings on the MOS. The runway centerline is marked as a broken line and the edge markers which are hard plastic or metallic signs are used to delineate the boundaries of the MOS. Any existing runway markings that could cause confusion regarding the location of the MOS should be eliminated.

AIRCRAFT ARRESTING SYSTEMS

Aircraft arresting systems are used for the possible engagement of high speed fighters returning to the base with battle damage or other emergencies. Additionally, for those occasions when a short MOS is employed during aircraft recovery operations, an arresting system will be needed even for routine aircraft recovery operations.

The three primary types of arresting systems are expeditionary, mobile, and permanently installed. The expeditionary arresting systems are those which can be relocated to a point of operation and quickly set up to engage landing aircraft. Depending upon the amount of time available for installation, the configuration of these systems in their expeditionary location can range from expedient to a permanent installation. The BAK-12 system is a component of the War Reserve Materiel (WRM) and will be readily available for wartime contingencies. Mobile Aircraft Arresting Systems (MAAS) provide an arresting system capable of rapid deployment in support of combat air operations from bomb-damaged runways, alternate bases, or forward operating areas in a postattack environment.

It is unlikely that an Army unit will conduct repair of arresting systems. Yet, to repair arresting systems, every effort should be made to first replace damaged components with parts which were designed specifically for use in an arresting system.

RUNWAY LIGHTING SYSTEMS

There are two basic approaches to solving the problem of damaged air base lighting systems--portable lighting systems and repair of existing lighting systems.

Power Supply

An adequate power supply must be available to return a damaged runway lighting system to operation. if the main base power and the air base lighting vault are still operational, the first consideration should be to reconnect or reroute feeder lines from the vault to the nearest source of base power. if the main base power system is not operational, or it is not feasible to reconnect an operational vault to base power, the use of generators is the alternative. Since an operational runway has highest priority in base recovery activities, the acquisition of generators should

not pose a problem. Depending on runway location, connecting the runway lighting system to an off-base, commercial power supply might also be a viable option.

Cable Connection

It is likely that parts of the underground cable system will also be disrupted. The most expedient way to repair this type of damage is to use the existing system to the maximum extent by splicing broken cable and looping around more extensive breaks with replacement cable.

If the lighting system is extensively damaged or the selected MOS does not lend itself to the use of an existing lighting system, new cables must be run to support a new lighting system. In either situation, "expedient" is the key word. Extra time should not be devoted to burying cable repairs or new cables unless required for safe aircraft operations. Running the cables above ground expedites repairs and saves considerable time for other critical repair tasks. More permanent repairs and burying of cables can be accomplished after the emergency conditions subside. Remember, it is desirable to use standard runway lighting cable for repairs. Any available electrical cable with a voltage and current rating equivalent to that required by the lighting system may be substituted.

Runway System Lights

Bulbs and fixtures are probably the most vulnerable components of the runway lighting system. Because of their exposed locations, these components can suffer damage from a variety of war-related causes. In restoring these components to use, the first action is the simple repair or replacement of damaged parts. If the fixtures are not damaged, replacement of broken or inoperative bulbs should suffice. If replacement bulbs are scarce or unavailable, consider leaving every other bulb out of the circuit. A general outline of the runway will have to suffice for emergency operations. Consideration should also be given to alternate sources of parts. If, for example, the air base has multiple runways, bulbs and other components may be salvaged from one runway to light another. As a last resort, bulbs and fixtures which are not commonly used in runway lighting systems may be jury-rigged for mission accomplishment under emergency conditions.

Air Navigation Aids

The NAVAIDS assist pilots in making precise approaches to the base and are vital for effective control of air traffic. The more common types of NAVAIDS found in a base are tactical air navigation (TACAN), instrument landing systems (ILS), beacon, radios, and windsocks. Although the operation and repair of these systems is not an Army engineer responsibility, Army engineers may assist in the restoration of utilities and NAVAID structures, and site clearing. The primary utility support to most NAVAIDS is electrical power to operate the system. Structural support could vary from a simple platform to support a radio antenna to extensive shoring of a TACAN facility. Since many NAVAIDS require a line-of-sight for proper operation, the Army engineering force may have to assist in site clearing following a hostile attack.

AIR BASE UTILITIES

At many air bases, water pipes, electric cables, and other utility lines run alongside or underneath runways and taxiways. Conventional attacks on the air bases are likely to disrupt some of these pipes and cables. If this damage is in a crater located on the MOS, the damage will be repaired by laying a bypass around the crater. Two joints will be required to connect the bypass into the main line. Most bases maintain stocks of rapidly installed joints of various sizes used to repair--

- Fuel lines.
- Water pipes.
- High-voltage electrical cables.
- Public address systems and telephone cables.
- Compressed air lines.
- Heating system lines.
- Sewer pipes.

Figure 7-1 illustrates the bypass repair of a utility line running parallel to a runway. Figure 7-2 illustrates the bypass repair of a utility system crossing a runway.

**FIGURE 7-1. EXPOSED CABLE BYPASS
OF UTILITY LINE PARALLEL TO RUNWAY**

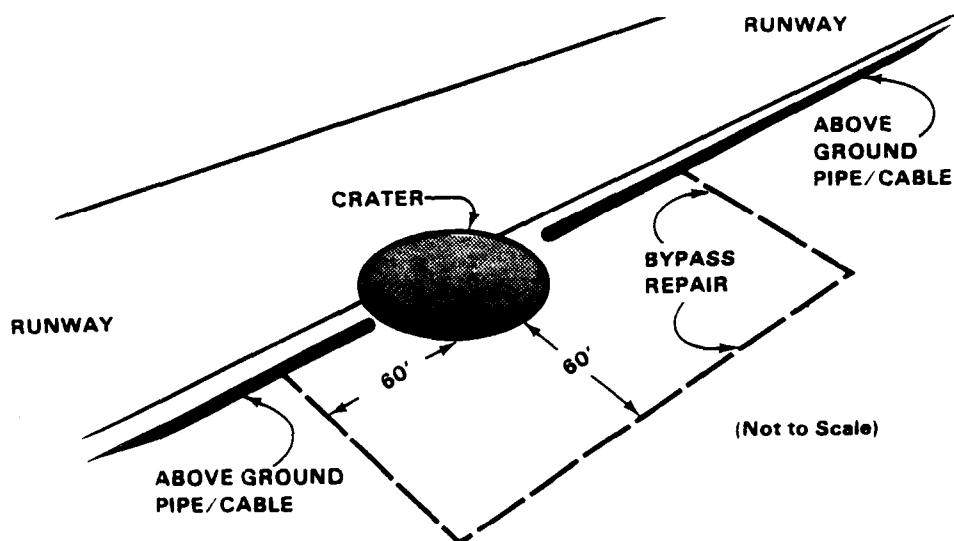

**FIGURE 7-2. BURIED CABLE BYPASS
OF UTILITY LINE CROSSING THE RUNWAY**

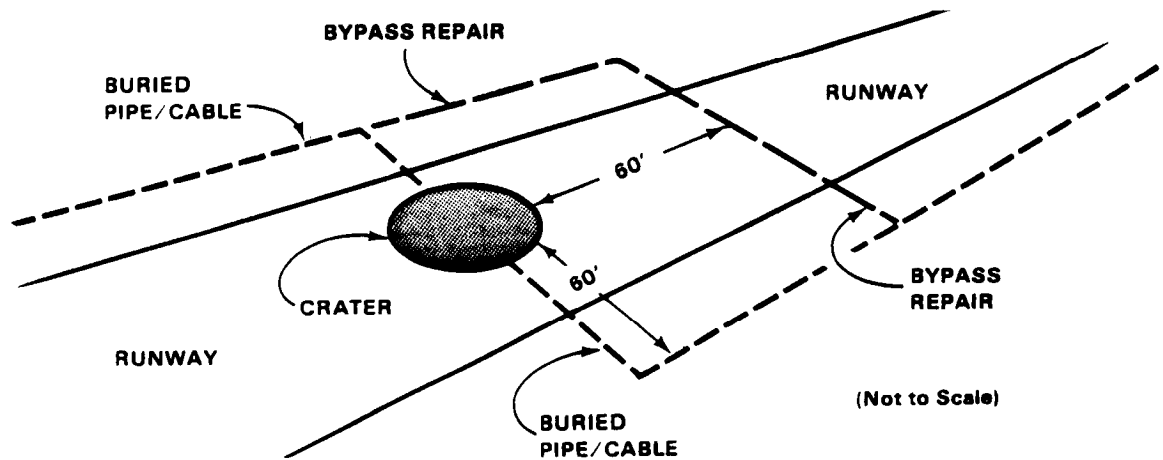

ELECTRICAL SYSTEM

Power for air base lighting, NAVAIDS, communication centers, command posts, medical facilities, and other important activities must be restored quickly in order for the base to fully resume its operational mission. Downed or damaged electrical lines can be expected during attacks. In such instances, the repair or isolation of life-threatening electrical hazards must receive high priority. The high voltages associated with an electrical system make it especially important to observe proper safety rules during repair activities.

Expedient Electrical Repairs

The electrical system supporting an air base consists of several components--production, distribution, and interior wiring. Each component of the system should be considered in terms of its anticipated damage during a contingency and by identifying expedient repair techniques deemed adequate to remedy the damage.

- **Production Systems.** Electrical power on an air base originates from one of two sources--the connection to an off-base commercial power system or an independent power production plant on the base. Repair of damage to the off-base power source or the principal feeder lines is normally the responsibility of the host nation. If the commercial source of power is interrupted, normally the only alternative is to disconnect the impaired power source from the distribution system and to substitute generators to power vital facilities. However, essential facilities already have dedicated, standby generators with an automatic transfer capability to maintain operations in the event the prime power is lost.
 - Generators, mentioned earlier as an alternate power source, will probably be in short supply, making it imperative that these vital assets be positioned and maintained properly.

- Generators should be used to provide power to only those facilities that are absolutely crucial to base operations. Damaged or inoperative generators may be used as a source of spare parts. Components and parts from several damaged generators may be reassembled to produce one usable machine. Equipment other than disabled generators may serve as a source of repair parts, for example, injectors from a diesel engine in a destroyed vehicle can be salvaged and adapted to a generator engine.
- Distribution System. The power distribution system may consist of overhead power lines, underground power lines, or a combination of the two. Overhead power lines and the associated utility poles are likely to suffer extensive damage during an attack. An underground system is still vulnerable to the effects of enemy munitions.
 - The first action is the isolation of those damaged areas presenting life-threatening hazards to personnel or pose the potential for additional property damage. Once initial isolation is accomplished, DCC personnel, using base utility plans and maps, determine how the system can be rerouted to bypass damaged areas in order to restore electrical power to vital base facilities.
 - When rerouting around damaged areas, nonstandard materials can be used provided they do not jeopardize safety. If capable of carrying the required loads, wires and cables of different sizes, or normally designed for other uses, can be substituted as expedient power lines. Additionally, conductors, wire, and other components can be salvaged from unimportant or damaged lines.
 - Expedient repair of transformers can be accomplished if the damage is not too extensive. Cracks or holes in the tanks of the transformers can be patched by welding, provided testing indicates that internal parts have not been damaged. Transformers can be returned to service after being thoroughly dried and when lost or contaminated transformer oil has been replaced. Oil from damaged transformers must be filtered before being reused, and motor oil is not a satisfactory substitute for transformer use. (A transformer requires a highly refined mineral oil, free from moisture or other impurities.)
- Interior Wiring. Expedient repairs to the interior wiring of a structure depend on the extent of the damage and the criticality of the facility. If the facility is not critical to current air base recovery operation, repairs are usually deferred until additional resources are available. For facilities considered essential to air base operations, determine, to the minimum level, electrical services needed.
 - In making expedient repairs to the interior wiring, undamaged structural wiring is used to the maximum extent possible. This will reduce repair time and result in fewer exposed live circuits when the facility is returned to operation. As in the distribution systems, damaged areas can be bypassed with new wiring to complete a vital circuit.
 - In bypassing damaged areas or in running temporary lines into a structure, wiring can be run across floors and other building surfaces to expedite repairs.

However, if the facility will be subject to a high volume of personnel traffic, the wiring should be fastened to the wall or ceiling to prevent further damage or hazards to personnel. The temporary wiring does not have to be concealed to present a finished appearance; it only needs to be functional and away from heavy traffic.

- Another important consideration in the expedient repair of interior electrical systems is the supply of wiring, switches, and associated hardware needed to make repairs. Depending on the extent of damage, base supply sources may not have adequate levels to provide for all repair needs. In these cases, cannibalization and substitution become very important. At theater locations many components will be of foreign manufacture and not readily available through US supply channels, making it imperative that repair crews salvage as much as possible. Structures declared irreparable may contain switches, wiring, and other hardware that can be used to restore electrical services to other structures. A note of caution: do not conflict additional damage during salvage attempts. Structures being salvaged may have to be rehabilitated in the future.

WATER SYSTEM

Water is another important utility requiring quick restoration following a disaster of hostile attack. Water systems will normally have a high priority for repair for fire fighting, decontamination uses, sanitation requirements, and the need for potable water for drinking, cooking, and hygiene.

Water System Components

The major components of any water supply system are source, treatment, storage, and distribution. Application of expedient repair methods for the components of the water system requires a basic understanding of how the system operates and presumes that preplanned isolation procedures have been established and vulnerable components have been identified.

- **Water Source.** The air base source of water may be a commercial supplier, a groundwater source, or a surface water source. Damage to a commercial water supply during an attack will normally consist of a ruptured or blocked supply line reducing or eliminating the base water supply.
 - Groundwater sources (water pumped from below the surface), are probably the least vulnerable supply sources. It can be assumed that hostile attacks would not destroy a groundwater source. Base attacks could, however, cause damage to the well and pumping systems that give the air base access to this source. Wells could be partially filled with debris, well walls damaged, and pumping facilities damaged or destroyed entirely.
 - Surface water sources can be affected by various types of emergency situations. The NBC contaminants used during an enemy attack could make the source unusable. Conventional enemy munitions could diminish, divert, or stop access to a river or lake.

- **Treatment Facility.** The degree of treatment provided to the air base water supply will depend upon its source. For example, groundwater is normally free of contaminants such as silt and microorganisms. The treatment of groundwater is usually minor, but it should always be thoroughly tested to determine the treatment required. Surface water sources, on the other hand, may require extensive treatment.
- **Storage Facility.** The water storage system on an air base may consist of underground reservoirs, elevated water tanks, open reservoirs, and temporary storage facilities. The most severe damage to the storage system could be a rupture causing loss of the stored water.
- **Distribution System.** The most extensive component of the base water system is the distribution network. The subterranean construction protects the distribution network from certain types of disasters, but a major enemy air attack is almost certain to disrupt some part of the distribution network's dispersed layout. Damage to the distribution system is normally confined to pumps, valves, and water mains. Water mains may be broken in several locations resulting in massive leaks causing immediate damage, as well as numerous hidden leaks producing delayed damage in the form of undermined streets or structures.

Expedient Repair of Water System Damage

Expedient repair of the water system involves the determination of minimum air base requirements and the establishment of a temporary supply system through bypass and repair operations.

- **Source.** If the primary source of water has been interrupted, connections to the original source must be restored or a new source developed. The primary effort should be directed to restoring the connection to the original source, normally a less time-consuming effort than developing a new water supply. If the damage is not too extensive, expedient repairs or a quick bypass operation might restore the supply. If the existing source of water cannot be restored, the Air Force civil engineering recovery force must develop alternative sources.
- **Groundwater.** Development of a groundwater source produces both advantages and disadvantages. Generally, groundwater should be considered a secondary source if a source of surface water can be developed. Some of the advantages of using a groundwater source include--
 - **Availability.** Groundwater is sometimes available where surface water is not, such as in desert regions. Additionally, groundwater can sometimes be located at times when there is no surface water, as in dry seasons or during drought.
 - **Purity.** Unlike surface water, groundwater is normally free of major contaminants. Also, groundwater will usually be at a cool, constant temperature.

- Proximity. Wells can often be drilled in proximity to the user, eliminating water transportation problems.
- Resistance to Contamination. Groundwater is not as vulnerable to contamination during NBC attacks. In fact, the only way groundwater can be contaminated quickly is by placing a harmful agent directly in the well.

One of the major disadvantages of developing a groundwater source is the time involved. Other disadvantages include--

- Need for a Well. Groundwater cannot be reached without a well. Well drilling necessitates specially trained personnel and sophisticated equipment.
 - Detection of Groundwater. Groundwater is not readily visible and cannot normally be detected without special techniques and equipment.
 - Pumping Requirement. After a well has been constructed, a pump is needed to draw and transport the water from the ground to the treatment location or the distribution system, to be set up to draw the water to the surface. In addition, some type of transportation system must be constructed to carry the water to the treatment plant or user. Standard water pipe, polyvinyl chloride (PVC) pipe, or fire hose may be used for this purpose. In extreme cases, the water may have to be transported by water trailers or 55-gallon drums loaded onto a cargo truck.
- Surface Water, There are numerous sources of surface water. Lakes, rivers, streams, and oceans can all be considered as possible sources. Whether it is feasible to use one of these sources to supply the water requirements of an air base will depend on a number of factors. Some of the most important considerations are supply, NBC contamination, purity, and proximity.
 - Treatment Facilities. The expedient restoration of water treatment capabilities may consist of repairs to an existing treatment plant or the installation of portable water treatment units. The importance of restoring the water treatment facility will depend upon the quality of the base water source following an emergency. If the source is relatively free of contaminants, treatment plant repairs or installation of portable treatment equipment may be of less importance than other base repairs. If water treatment is necessary and the treatment plant is beyond repair or the base does not possess a treatment facility, it may be necessary to use expedient water treatment equipment. The two most common expedient water treatment systems available to the Air Force civil engineering forces are the conventional water purification unit and the reverse osmosis water purification unit (ROWPU).
 - Storage Facilities. Expedient repair of leaks or ruptures to water storage facilities is essential to stem the loss of water supplies. If connections to the primary water source are interrupted, the water contained in storage facilities may be the only water available for human consumption, fire fighting, and other vital needs.

- Expedient repair of damaged water storage facilities may involve elevated water towers, ground level water tanks, or various types of reservoirs. Ruptures and other damage to these facilities can be sealed from the inside using rubber patches, epoxy, and other quick-setting, impervious materials.
- When conventional base water storage facilities are damaged or additional storage space is required, swimming pools and similar watertight facilities make excellent alternate reservoirs.
- Other expedient water storage alternatives include flexible bladders ranging in size up to 50,000-gallon capacity, water distribution trucks, water trailers, Lyster bags, 5- and 10-gallon water coolers, and 55-gallon drums. An above-ground reservoir can be constructed using sandbags or earth berms lined with plastic sheeting to make it watertight. A considerable amount of water is stored within the pipelines themselves. For example, a 6-inch pipeline, two miles long contains approximately 16,000 gallons when full.
- **Distribution System.** The water mains, valves, and pipes that form the water distribution network are the most extensive part of the water utility system. The most common damage to the distribution network will be ruptured lines with numerous leaks and loss of pressure. The widely dispersed distribution system will dictate simultaneous repairs at several locations. It is essential that base utility plans are available to determine the layout of the system. By using these plans, the required flow could possibly be rerouted through undamaged lines, bypassing the damaged sections. If the damage to the water system does not permit rerouting using the existing system, temporary repairs must bridge damaged sections. Water may be shunted around these breaks using standard water pipe, fire hose, or other suitable tubing adequate to carry the needed flow. To facilitate repairs, these bypass connections may be run above ground. For example, a section of fire hose may be connected between two fire hydrants to carry the water flow around a break in the water main. Smaller leaks in the distribution network can be quickly sealed using temporary sleeves or wooden plugs. If time permits and the necessary tools are available, holes are reamed to a larger size, threaded, and fitted with a standard metal pipe plug.

GAS SYSTEM

Damage to a base natural gas system must be dealt with rapidly to ensure that this potentially dangerous material is effectively contained. The most expedient method dealing with gas system leaks is to shut off the gas supply at the main access point to the base. Since gas is not normally essential for base operations, the system can usually remain off until time and resources are available for repairs, unless it is winter time and the base has gas heat.

Emergency Cut-off Procedures

If it is not possible to cut off the gas supply through the use of existing valves, gas main bags or gas stoppers may be required. Gas main bags are canvas or rubber bags which can be inserted into a gas main and inflated until it fills the pipe and stops the gas flow. The gas stopper consists of oiled or rubber-coated canvas stretched over a flexible steel frame. The edge of the stopper forms a seal with the interior of the gas main, thereby stopping the gas flow. To seal a main with a gas bag, the rubber or canvas bag is inserted through a hole in the main (a hole created by damage, removal of a riser, or access part). If the interior of the pipe is coated with tar or oil, canvas bags are necessary. The bag is then inflated through a piece of attached tubing until it fills the pipe and stops the gas flow. To use a gas stopper, the frame is squeezed together and inserted into the hole in the gas main. After the stopper is in the pipe, it is restored to its circular shape through the use of wire levers attached to the frame. The gas stopper can then be adjusted to shut off the gas flow. In larger mains, it is safer to use both bag and stopper.

Expedient Repairs of Gas Systems

As mentioned earlier, it is best to simply cut off gas systems and make permanent repairs later when the emergency has subsided. However, certain conditions may call for some immediate expedient repairs to prevent danger to personnel or to provide limited gas service.

- **Venting of Gas Accumulations.** After the main gas supply is shut off, buildings and other areas must be checked for the presence of dangerous gas accumulations. The presence of gas can be detected by the individual's sense of smell. The sense of smell cannot always be depended on to detect leaks because gas can lose its odor while traveling through the ground. Any accumulations should be vented to the outside to reduce the potential for asphyxiation or explosion.
- **Repair of Broken or Punctured Gas Pipes.** There may be conditions following an emergency when gas must be supplied to certain facilities for essential operations. For example, the dining hall may have no alternate method for preparation of food for the recovery force; or the hospital may need hot water for crucial medical services and have no other source of energy for water heaters. During periods of cold weather, gas may be the only source of heat for certain mission-critical base facilities. Under any of these conditions, leaking or ruptured gas lines may require patching. If the leak is small and involves low pressure gas pipes, a sealant may be used in conjunction with a pressure mold to close the opening. The sealant should be a product which does not break down in the presence of natural gas. Larger leaks and pipe breaks can be repaired using various types of mechanical clamps.

HEATING SYSTEM

Depending on weather conditions at the time of a hostile attack, repairing damage to the heating system can range in importance from critical to insignificant. Unless the air base is undergoing a period of severe cold, repairs on the system can probably be delayed through the use of

space heaters and the wearing of additional clothing. If repairs must be made to the system, efforts are concentrated on minimum repairs necessary to return some measure of heat to base facilities.

Repairs to Central Heating Systems

For those bases that have a large central heating system, damage following a disaster can be widely dispersed. There may be damage to the production plant, as well as the distribution system. The feasibility of expedient repairs to the heating system will depend on the amount of damage incurred during the emergency. For example, if a bomb explosion causes a large rupture of the central boiler, it is unlikely that expedient repair techniques will suffice. On the other hand, a break in one of the pipes leading from the boiler could probably be repaired expediently.

Repairs to the Distribution System

The high heat and pressure associated with the heating system are characteristics that preclude the use of many expedient methods and materials used to repair the water distribution system. For example, temporary connectors, such as fire hoses, which are effective in bridging damage to the water distribution system, may not tolerate the high temperatures and pressures of a heat distribution line. Similarly, a standard sealer or joint compound which could patch a water leak will break down when applied to a steam line.

SEWAGE SYSTEM

Improper disposal of sewage in the aftermath of enemy attack will compound air base recovery problems. If the sewage enters a water supply, an outbreak of intestinal diseases is almost certain to occur. To prevent such outbreaks, Army engineers may have to repair damage to existing sewer systems as well as provide temporary sanitation facilities. The priority of these repairs will be based on an estimate of potential hazard to the air base population.

Classification of Air Base Sewage

Sewage may be divided into several classifications according to its source. These classifications will determine the immediate need for sewer rehabilitation. The two primary types of sewage on most air bases are domestic and storm sewage. A third type, industrial waste, is not common to most bases.

Sewage System Operation

The major components of the sewage system consist of facilities for collecting, pumping, treating, and disposing of sewage. The basic collecting system consists of a series of branch, lateral, main, and trunk sewers leading from various base structures. Raw sewage moves through the collection system to a central point for treatment and eventual disposal. At any point along the system where gravity is not sufficient to move the sewage, a pump or lift station may be required.

Sewage treatment plants vary in complexity according to the characteristics of the influent and the degree of treatment required prior to discharge. Effluent standards, set by national and local regulations, determine the degree of treatment.

Expedient Sewage System Repairs

Expedient sewer repairs should consist of only the minimum work required to prevent the outbreak of disease. For example, if a ruptured sewer line results in sewage leakage in an unoccupied area of the base which does not threaten water sources, repairs can be delayed until emergency conditions subside.

- **Sewer Lines.** The sewer lines are the most essential elements of the sewage system. If collection lines are blocked or interrupted, the sewage will be unable to reach the treatment plant and may cause contamination. To restore damaged sewer lines, an attempt should be made to route around the damaged area using any available pipe (4-inch diameter minimum) which will carry an adequate flow. If the situation is critical, service can be restored temporarily by pumping from an upstream manhole, routing around the damaged section into a downstream manhole. If the sewer is completely blocked or severely damaged, an open channel can be dug. Where storm and sanitary sewers are separate, it may be possible to divert sanitary sewage through a storm sewer to a suitable outlet. A prime concern when making any expedient repair or modification on sewer lines is to prevent the contamination of the potable water system. Sewer lines and water lines must not be placed in the same trench. If lines cross, the sewer line should always cross below the water line and should never be laid adjacent to a water supply source.
- **Lift Stations.** When sewage pumping stations cannot be repaired expeditiously using available replacement parts or parts cannibalized from other stations, portable pumps should be substituted. If pumps are not available, consider rerouting past the lift station with pipe or open channels to provide for a gravity flow.
- **Treatment Plants.** Severely damaged treatment plants may have to be bypassed. Settling and digestion tanks and filters can usually be repaired with standard construction methods and materials. Sludge beds are practically indestructible. Repair to treatment plant machinery should be attempted using cannibalization or improvised methods and materials. If activated sludge plants have lost their air compressors, they may be operated as sedimentation or septic tanks. Such treatment, together with chlorination, provides a reasonable degree of sewage purification.

Field Sanitation Methods

Even with qualified repair personnel and adequate materials, there may be situations where damage to the sewage system is too widespread for expedient repair. Under these conditions, the civil engineering force must resort to proven field sanitation methods.

Human Wastes. Field expedients for the disposal of human waste are--

- Straddle trench latrines.
- Deep pit latrines.
- Burn-out latrines.
- Mound latrines.
- Bored hole latrines.
- Pail latrines.
- Urine soakage pits.

The type of latrine to be constructed depends on the length of time the facility will be in use, the groundwater level, and soil conditions. To protect water from contamination, never extend the depth of a latrine pit or trench to the underground water level.

- Liquid Waste. Most field expedient methods for disposal of liquid wastes associated with showers, lavatories, and kitchens involve disposal into the soil. Soakage pits or soakage trenches are constructed to hold the liquid waste to allow gradual percolation into the soil. For the soil to absorb these liquids, grease, soap, and other solid particles must first be removed. This is accomplished through the use of a grease trap. In areas where the soil composition does not lend itself to use of soakage pits or trenches, evaporation beds may be used provided the climate is hot and dry.

APPENDIX A

AIR FORCE CRATER REPAIR

Joint service regulation AR 415-30/AFR 93-10 requires the Air Force to support its own needs in the emergency repair of war damage to air bases. This requires the minimum amount of immediate repair to damaged facilities necessary to accomplish the air mission. After an air attack, the runways and taxiways must be repaired to a sufficiently high standard for operations to be resumed with minimal risk to the aircraft. The surface roughness of a repaired air base must not be outside the tolerances required for the particular aircraft or combinations of aircraft. To achieve the most rapid repair possible while also meeting the required standards, the Air Force has developed two main types of crater repair methods:

- Crushed stone with either a fiberglass or AM-2 mat.
- Precast concrete slabs.

Upon completion of emergency repairs and resumption of the air mission, Army engineers may then execute their "beyond emergency repair" mission.

GENERAL CRATER REPAIR ACTIVITIES

After selection of the MOS and clearance of UXO, the following activities must be accomplished for any crater repair method:

- Clear debris from around the lip of the crater so that the upheaved pavement is visible. This can be done with front-end loaders, bulldozers, and graders. Continue clearing and sweeping more scattered debris from around the crater. This is an ongoing process which must begin immediately at the start of repair efforts. If the air base surface is asphalt cement, bulldozer tracks will damage the surface, especially in warm weather. Work the bulldozer from the side of the runway or taxiway and keep its movement to a minimum on the undamaged portions of the air base. Bulldozer tracks will not significantly damage a concrete-surfaced air base.
- Measure the upheaval around the crater and determine how much upheaved pavement must be broken out. This is called a "surface roughness check." To properly execute such a check, it is first necessary to discuss the Air Force's method for achieving quality repairs. The repair quality specified is a maximum allowable upheaval above the undisturbed pavement level. The flat (not necessarily horizontal) surface of the repair must not exceed the vertical tolerance by more than

1/2 inch (see Figure A-1). The five repair qualities that can be specified are 4 1/2 inches, 3 inches, 1 1/2 inches, 1 inch, and 0 inches of upheaval above the undisturbed pavement surface. Repair quality is measured by making surface roughness checks. Such checks consist of the following measurements:

- Slope of the upheaved pavement.
- Height of the upheaval above the level of the undamaged runway surface.
- Sag of the repair surface below a theoretical straightline repair surface.

FIGURE A-1. REPAIR QUALITY TOLERANCE

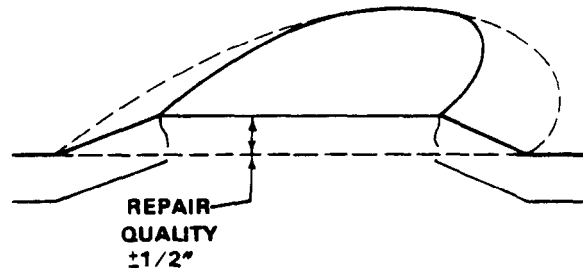

The instruments needed for surface roughness checks are two upheaval marker posts, a string line (see Figure A-2), and a change of slope straight edge (see Figure A-3). To determine the amount of upheaved pavement to break out--

- Set the string line at the repair quality height mark on the upheaval marker posts.
- Move the string around the crater and mark the pavement where the upheaval is higher than the level of the string line (see Figure A-4).
- Check the slope of the upheaved pavement that will not be broken out with the straightedge. The maximum slope value for the crater being repaired will be provided by the BCE. The slope value varies based upon the type of aircraft, frequency of damage, and speed of aircraft. The 5 percent change of slope straightedge shown in Figure A-3 is merely an example of one of the types which may be required to repair the crater to acceptable standards.
- The 1/2-inch tolerance on the surface of the completed repair is checked by stretching the string line across the crater in a direction parallel to the MOS centerline. The string is lowered until it just touches the surface of the repair. The reading on both upheaval marker posts should not exceed the specified repair quality by more than 1/2 inch.
- The vertical downward distance from the string line to the repair surface should not

FIGURE A-2. MAXIMUM ALLOWABLE UPHEAVAL INSPECTION

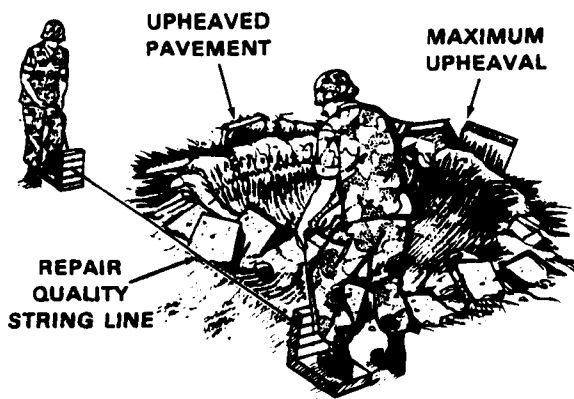
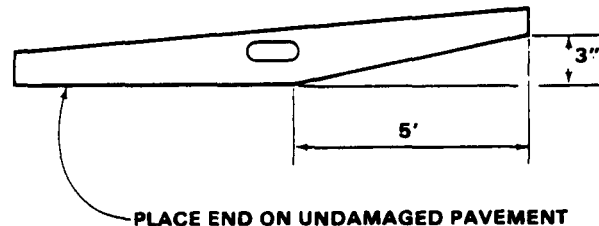

FIGURE A-3. FIVE PERCENT CHANGE OF SLOPE



exceed 1 inch. These flatness checks should be made along three lines parallel to the MOS centerline. One line is along the MOS centerline (or along the centerline of the repair if the whole repair is on one side of the MOS), and the other two are halfway between this centerline and the edges of the crater.

- Mark the pavement with paint or wax crayon to show the required circumference of the repaired crater.

For the crushed stone method, break back the upheaved pavement to the marks made during the surface roughness check. This job can be done with the blade or the rippers of a bulldozer. For the precast concrete slab method, the pavement must be cut with concrete saws to form a square or rectangle.

Any water in the crater should be removed. This can be accomplished with a pneumatic pump. Fill the crater with ejects (no material with a dimension greater than 12 inches) to 18 to 24 inches below, or with ballast rock to about 6 inches below the runway surface, depending on the repair method being used (see Figure A-5). Debris can be used for backfill if it is not wet and sticky, and if the crater is not partly filled with water. If the debris is wet or the crater contains water, the crater should be backfilled with ballast rock, which is brought in dump trucks from stockpiles on the air base.

Level the debris or ballast rock fill in the crater with the bulldozer blade or backblading with a bucket loader. The backwards and forwards movement of the equipment is generally sufficient to provide the small amount of compaction required. However, if leveling is accomplished rapidly due to operator proficiency, it may be necessary to spend additional time compacting the backfill. At least two or three coverages of the surface should be obtained.

Place an impervious membrane on top of the debris or ballast rock. This prevents inflow of water into the aggregate fill above. Also, the membrane prevents the higher quality stone base

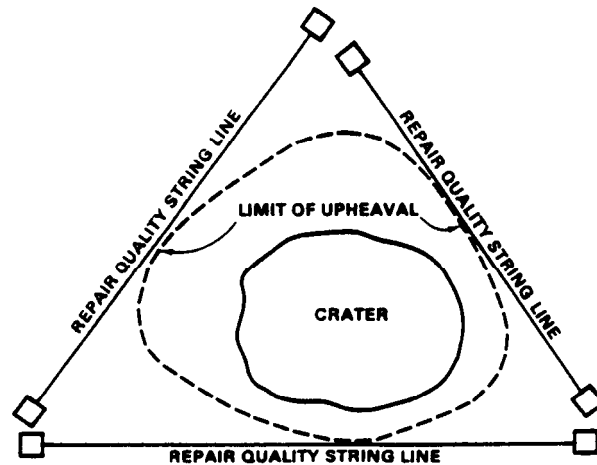
FIGURE A-4. LIMIT OF UPHEAVAL TO BREAK OUT

or leveling course from settling into the ejects or ballast rock and causing short-term differential settlement in the runway surface.

For the precast concrete slab method, place a leveling course of 4 to 5 inches of uniform 3/8-inch sized gravel and compact as necessary. For the crushed stone method, overfill the crater with crushed stone and level the surface about 4 inches above the runway surface. Compact the crushed stone surface with at least four coverages of a 10-ton vibrating roller. One coverage means sufficient passes of the roller over the crater to traffic every point on the crater surface once. The Air Force has 10-ton vibrating rollers. Army combat heavy units have 15-ton vibrating rollers which are also satisfactory for compacting crushed stone. The Army also has a 10- to 14-ton, non-vibratory, steel, wheel roller used exclusively for rolling asphalt. Rolling crushed stone with this roller will damage the smooth finish of the steel wheels. Therefore, while a 10- to 14-ton roller could be used for compacting the crushed stone, the roller will be unfit for future asphalt operations.

For the crushed stone method, skim off the surplus crushed stone to leave a dome of 1 1/2 inches above the pavement. This is best done with a grader. Compact the crushed stone again with at least four coverages of a 10-ton vibratory roller. Skim off surplus crushed stone to leave a surface almost flush with the surrounding pavement. The goal of this process is to have a relatively flat and level surface upon which to place either the fiberglass or AM-2 mat.

For the precast concrete slab method, place the slabs onto the leveling course. Settle the slabs into the leveling course gravel by rolling two coverages with a 10-ton roller.

For the crushed stone method, check again to ensure the repaired surface meets the surface roughness criteria. Then place either an AM-2 landing mat or a fiberglass mat over the repair.

Conduct a final surface roughness check to ensure that the surface does not exceed tolerances. If it is not within tolerances, the repair is unacceptable. Repair the unacceptable areas using the procedures outlined above.

Sweep around the crater and continue sweeping the air base until the pavement surface is free of all debris.

CRUSHED STONE REPAIR WITH FOD COVER

A crushed stone repair is suitable for any size crater and would normally be used with a fiberglass or AM-2 landing mat over the top as a FOD cover. The crushed stone repair is composed of two specific actions, the filling of the crater with crushed stone and the placement of a cover.

“Crushed stone” refers to a high-quality, well-graded crushed stone (see Table A-1) . The specification for this well-graded crushed stone is 0 to 32 millimeters. There are three basic variations of backfilling with crushed stone. The method chosen depends upon ground conditions and the availability of stone.

TABLE A-1. GRADATION CURVE RANGE FOR A HIGH QUALITY, WELL-GRADED CRUSHED STONE

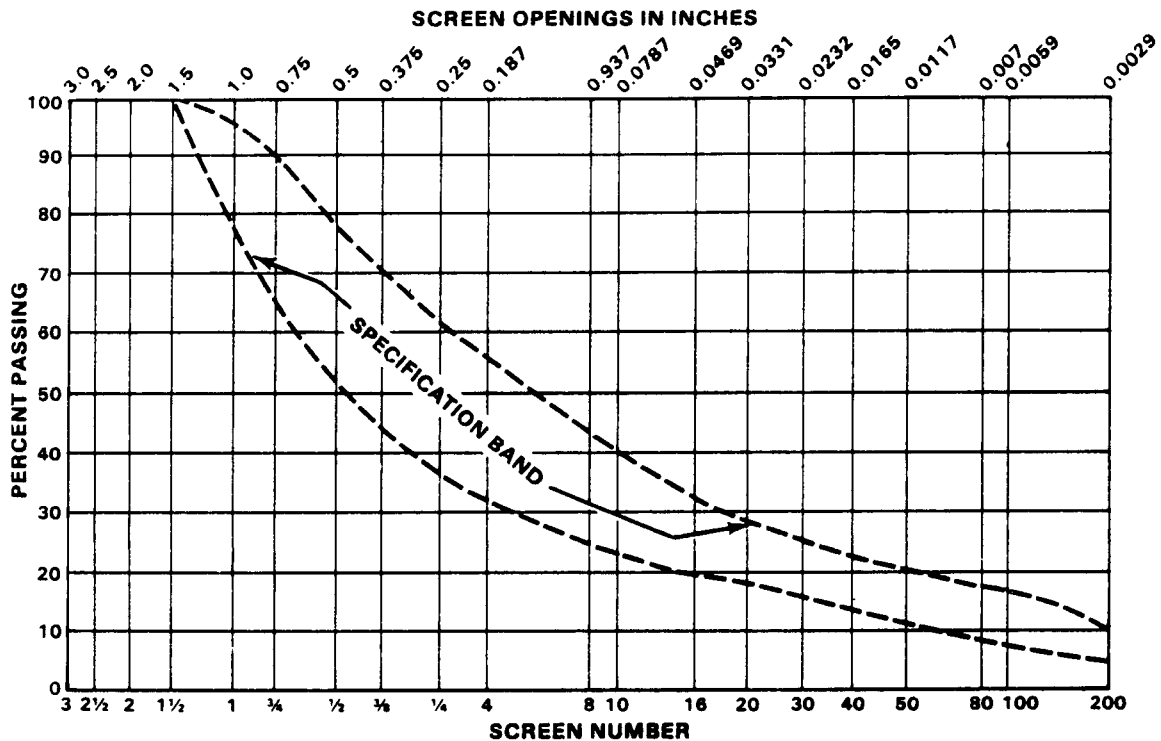

Normal Repair

This method is shown in Figure A-5 and involves backfilling the crater with debris to within 18 to 24 inches of the runway surface. Cover this layer with an impervious membrane. The crater is then overfilled by 4 inches with well-graded crushed stone. Use a grader to skim off the surplus crushed stone to leave a dome of 1 1/2 inches above the pavement. Compact the crushed stone again with at least four coverages of a 10-ton vibrating roller. Skim off the surplus crushed stone to leave a surface almost flush with the surrounding pavement. A fiberglass mat or an AM-2 landing mat is towed over the repair and bolted to the runway surface. This method assumes that the crater does not maintain standing water and that the debris backfill is reasonably firm (California Bearing Ratio (CBR) of 3 to 5).

FIGURE A-5. AIR FORCE CRUSHED STONE CRATER

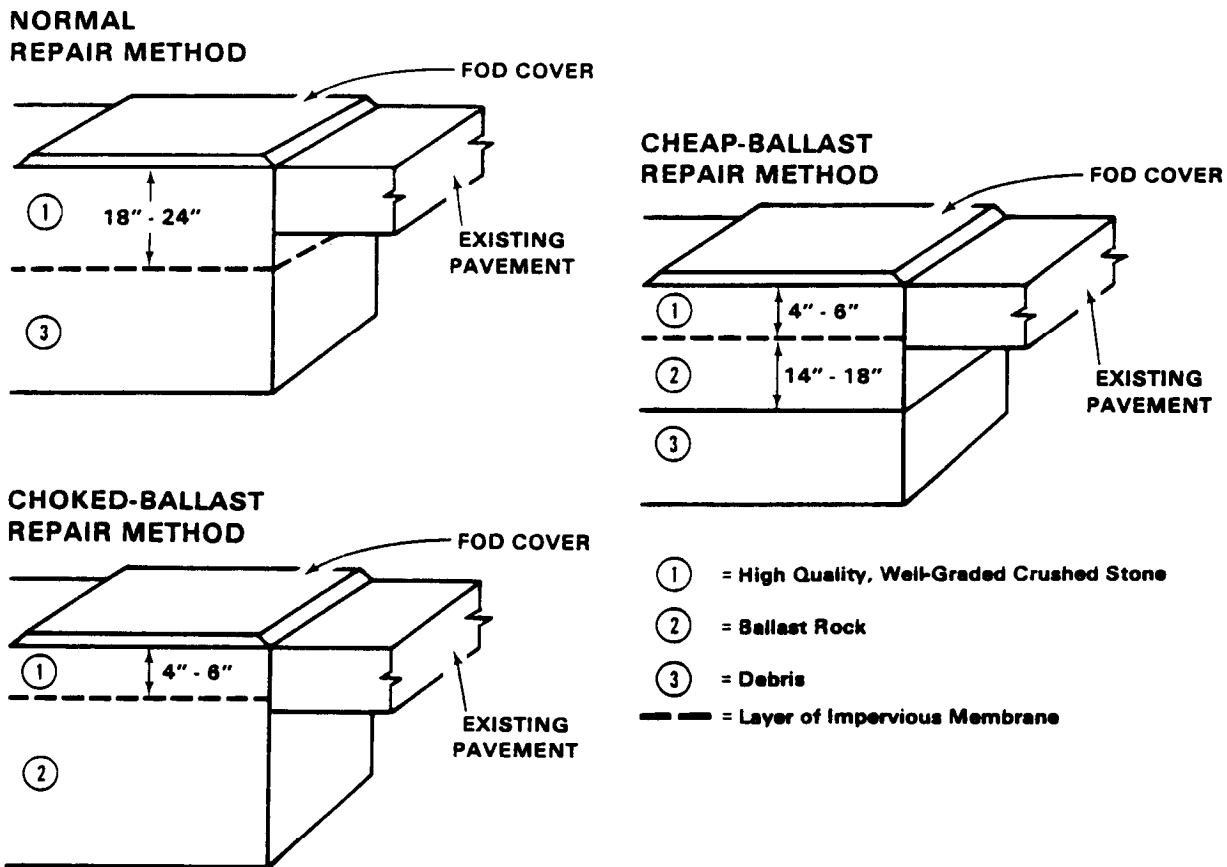

Choked-Ballast Repair

When the crater contains water or the debris is unsuitable for use as a backfill material, the crater is filled within 4 to 6 inches of the pavement surface with ballast rock (see Figure A-5). Table A-2 contains the gradation specifications for the ballast rock. The specification for this ballast rock in West Germany is 32 to 56 millimeters. Cover this layer with an impervious

**TABLE A-2. SPECIFICATIONS
FOR BALLAST ROCK**

U S STANDARD SIEVE SIZE	ALLOWABLE RANGE (WEIGHT % PASSING)
3 INCH	100
2½ INCH	90 - 100
2 INCH	35 - 100
1½ INCH	0 - 70
1 INCH	0 - 15
¾ INCH	0 - 10
½ INCH	0 - 5

membrane. The crater is then overfilled by 4 inches with well-graded crushed stone. Complete the procedures as with the normal repair.

Cheap-Ballast Repair

Stone for road construction is specified by maximum and minimum size. Since aggregate or concrete is specified by grading, it may be very expensive to buy well-graded crushed stone. This cheap-ballast repair method reduces the amount of well-graded crushed stone required by replacing it with cheaper ballast rock (see Figure A-5). This method is used where the crater does not contain water and the debris is suitable for backfill. The crater is filled with debris to within 18 to 24 inches of the surface. Ballast rock is added to within 4 to 6 inches of the surface. Cover this layer with an impervious membrane. The crater is then overfilled by 4 inches with well-graded crushed stone. Complete the procedures as with the normal repair.

FOD Covers

Use of FOD covers, such as fiberglass mats and AM-2 landing mats, help keep rain from seeping into and weakening water-susceptible fill materials. They also reduce the depth of ruts caused by aircraft traffic. Both fiberglass mats and AM-2 landing mats will provide some structural load-bearing capacity.

Fiberglass Mats

Fiberglass mats are made of two or more layers of fiberglass impregnated with either polyurethane or polyester resin. Older fiberglass mats were fabricated using polyester. The newer mat, which is available in greater quantities, is made of polyurethane. The acronym FRP stands for either the fiberglass reinforced polyurethane or the fiberglass reinforced polyester mat.

These FRP mats are fabricated at the air base during peacetime. They are 1/4 to 3/8 inches thick and are not flexible enough to be rolled up. They should therefore be stored flat in low stacks on gravel pads at the sides of runways or taxiways or on the floor of hangars or hardened aircraft shelters. Fiberglass mats are weakened by long exposure to fluids, particularly

paint remover and petroleum hydraulic fluid.

- **Placing FRP Mats.** The FRP mats are fabricated in small crater (30 by 30 feet) and large crater (50 by 60 feet) sizes. Place the 60-foot side of the large mat along the long axis of the MOS.
- The hauling crew tows FRP mats from their storage sites and deposits them along the side of the runway near each of the craters to be repaired. It is normally necessary to bring the mats over the grass, after UXO has been cleared, as the runway will be too crowded with RRR vehicles.
- After the crater is filled and compacted, an FRP mat-bolting team tows the mat over the crater, drills holes, and bolts the mat to the pavement.
- **Joining FRP Mats.** If the crater size prevents the use of a single FRP mat, two or more mats can be glued together. Place the FRP mats in their final positions over the damaged area with an overlap of 2 feet along the edge to be joined. A polyethylene sheet is placed under the joint to stop polyurethane from soaking into the stone underneath. A 12-inch wide strip of fiberglass, the full length of the joint, is placed between the mats with 6 inches showing (see Figure A-6). Mix the two-part polyurethane resin. Equal quantities of each component (by volume) are required. The resin can be mixed in a bucket. In addition, a catalyst may be required to accelerate setting at low temperatures (near or below freezing). Catalyst concentrations depend on the polyurethane formulation available. A two-minute set

FIGURE A-6. JOINING FRP MATS

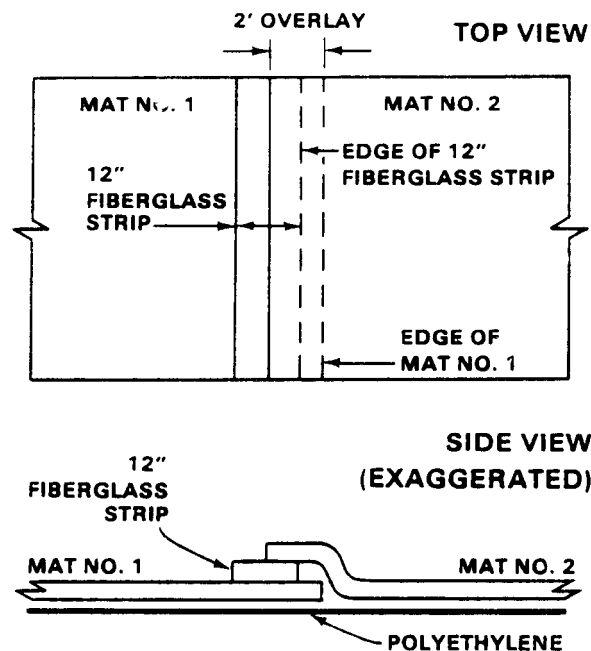

time is recommended for mat joining. Although the surfaces do not have to be completely dry, surface water should be removed from the areas to be joined. Pour and spread the polyurethane onto both sides of the fiberglass strip, using a roller or a squeegee. Place the fiberglass strip onto the bottom (No. 1) and then drop the other mat (No. 2) onto the fiberglass strip. The joint achieves adequate strength within 15 minutes. The Air Force is fielding an FRP mat that will be bolted together, rather than gled, covering a crater 50 by 60 feet.

- **Folding FRP Mats.** To allow FRP mats to be made air transportable for rapidly deployable forces, they can be made in panels. These panels are joined along the edges with fiberglass hinges and impregnated with a rubbery type of polyurethane. The size of the panels is dictated by the floor area of the transport aircraft. Folded FRP mats are dragged from the storage site and unfolded at the crater just before being bolted down. Alternatively, they can be unfolded in the storage area and towed flat. The mat should be tensioned to take slack out of the hinges by gripping and pulling on the edge of the mat. Folded FRP mats can be glued together with polyurethane to make larger patches, if necessary.
- **Anchoring FRP Mats.** It is recommended that FRP mats be predrilled for bolting. The normal anchoring system uses an expanding bolt, with a large-headed nut or "bushing."
- For concrete pavements, use Wej-It bolts (5-inch long by 5/8-inch diameter) or similar rock bolts (see Figure A-7). Use the correct size drill bit when placing any rock bolt, as the wedge cannot grip and then expand in an oversized hole. Drilling is a two-stage process as a 1 1/4-inch diameter, 1/2-inch deep recess must also be drilled into the pavement to take the stem of the bushing.

FIGURE A-7. WEJ-IT ANCHOR BOLT

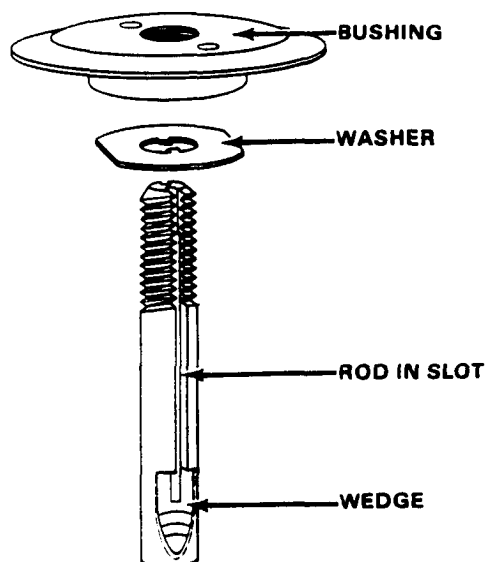

- Use longer 5/8-inch diameter Wej-It bolts or similar rock bolts for asphalt-overlaid and portland cement concrete pavements (usually about 6 inches of asphalt over an 8-inch thick concrete slab). The rock bolts must be long enough to allow the whole length of the wedge portion of the bolt to be embedded in and grip the concrete.
- A 5-inch long by 5/8-inch diameter bolt with wings or flattened edges to resist rotation (the Wej-It bolt with wedges removed) should be used in the case of flexible (asphalt) pavements where no portland concrete exists. Use a 1 1/2-inch diameter drill bit to make holes in the asphalt.
- Mix and pour polyurethane or other rapid-setting polymer material into each hole. When the bolt is inserted, the polyurethane level should be just below the underside of the countersunk bushing. Screw the bushing onto the top of the bolt, then put the bolt into the polyurethane-filled hole and step on it until the polyurethane has set. The catalyst in the polyurethane should be sufficient to allow a set in one minute. Finally, tighten the bushing down with a wrench.
- Tailhook Operations Over FRP Mats. When FRP mat crater repairs are used on parts of the runway over which aircraft tailhooks are to be dragged, special precautions must be taken to ensure that the tailhook does not get underneath the mat cover and tear it up. After the FRP mat has been bolted to the runway, a 6- to 9-inch wide ramp, made of mixed sand and polyurethane, should be placed on the runway surface along the leading edge of the mat to prevent tailhook damage. If the runway is wet, a series of 1-inch diameter holes (2 inches deep and at 1-foot centers) should be drilled along the line of the ramp to improve the bond to the pavement surface before placing the polyurethane and sand. A horizontal gap of 1 inch should be left between the edges of the mat and the ramp to allow the mat to be removed and replaced when maintenance is required. If polyurethane is in short supply, a polymer cement, such as Silikal (see Appendix C), can be used to make an expedient ramp to prevent tailhook damage to the mat.

AM-2 Landing Mat

A limited number of AM-2 landing mat kits are pre-positioned at some air bases to cover repaired craters. The size of one assembled kit is 54 feet wide by 77 1/2 feet long. The length can be shortened for small craters and lengthened for larger craters by using either fewer or more panels.

Due to an inadequate anchoring system, narrow patch width, and susceptibility to jet blast damage from outboard engines, AM-2 landing mat repairs are acceptable for fighter aircraft but inadequate for jet cargo aircraft strips. Additionally, the mats are 1 1/2 inches in height and this makes it hard to achieve surface roughness criteria. The 1 1/2-inch immediate change in height is the maximum which can be tolerated by most fighter aircraft in launch and recovery operations. Fabricated ramps should be employed on the leading edges of AM-2 landing mats to lessen the severity of this elevation change. However, AM-2 landing mats can be readily used to repair transport aircraft taxiways and aprons, provided that short-radius turns are not made over the mats.

If it is unavoidable to land cargo aircraft on AM-2 landing mats, these operations should be considered risky. If these landings are necessary, more intense maintenance efforts are required. After each landing--

- Inspect mats for damage.
- Tighten any loose anchor bolt nuts.
- Replace loose or bent anchor bolts.
- Restretch slack mats.

Warn pilots not to apply brakes while passing over an AM-2 landing mat. If AM-2 landing mats must be placed in an area where tailhooks are used, a 6- to 9-inch wide polyurethane and sand (or polymer cement) ramp should be trowelled up to the edge of the AM-2 landing mat ramp unit as a smooth transition from pavement to ramp surface.

Placing AM-2 landing mats is labor intensive and exhausting even in a non-NBC environment. The option of partial or total preassembly of some of the mats is recommended.

PRECAST CONCRETE SLAB REPAIR

A precast concrete slab repair is suitable for any size crater but requires the following additional items of equipment:

- Concrete cutting saws and extra blades.
- A water truck, to supply the concrete saw.
- A heavy-duty, pavement-breaking tool to allow accurate pavement breaking back to the line of the saw cut. (The Air Force has such an attachment for their multipurpose excavator.)
- A screeding beam for achieving an accurately leveled stone surface about 6 inches below pavement surface level (see Figure A-8).

Sequence of Repair

After the first surface roughness check has identified the amount of upheaval to be removed--

- Mark out a square or rectangle into which a whole number of standard-size slabs can be fitted. The standard slab size is 2 meters by 2 meters by 15 centimeters deep. Therefore, the sides of the cut around the crater should be a multiple of 2 meters in length. Use field telephone wire, in suitable lengths to form a "3-4-5" triangle, to set out the right angles. String is unsuitable because it shrinks when wet, and the length of a nylon cord varies with the tension applied at the ends.

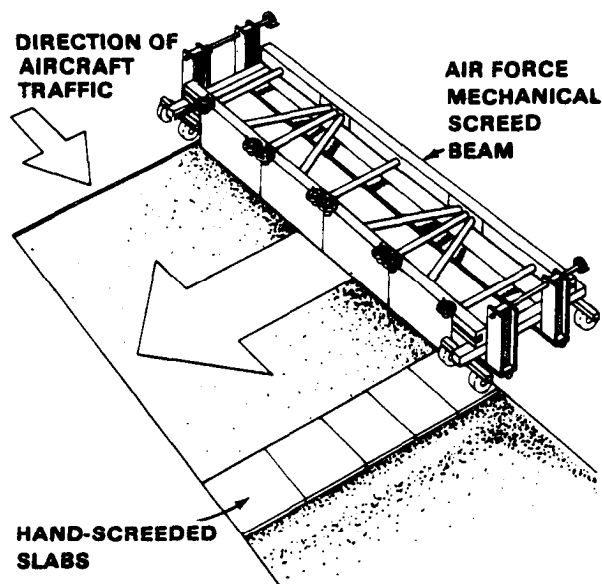
FIGURE A-8. PRECAST CONCRETE SLAB REPAIR

- Cut along the lines of the square or rectangle with the concrete saw. Since this process is laborious and time consuming, every available saw should be employed to minimize the cutting time.
- If the pavement consists only of concrete, the saw cut should be at least 6 inches deep.
- If the pavement is asphalt-overlaid concrete, the saw cut should penetrate at least 4 inches into the concrete layer.
- Using a pavement breaking tool, make a line of holes at 3-foot centers, parallel and about 1 foot inside (towards the middle of the crater) the cut line. Cracks radiating from these holes will break up the upheaved pavement into pieces small enough to be pulled out with the excavator bucket or with the ripper teeth of a bulldozer (see Figure A-9).
- Break out and remove the upheaved pavement.
- Fill the crater with ballast rock. Roughly level the surface of the ballast about 10 inches below the pavement surface level.
- Cover the ballast with a 4-to 5-inch thick layer of uniform 3/8-inch sized gravel as a leveling course.
- Using an Air Force mechanical screed beam, backblading with a bucket loader or using a grader spread the leveling course gravel to give a flat, smooth surface 4 inches below pavement surface level. Surplus gravel must be removed from the crater using either a bucket loader or hand shovels, An intermediate, hand-placed

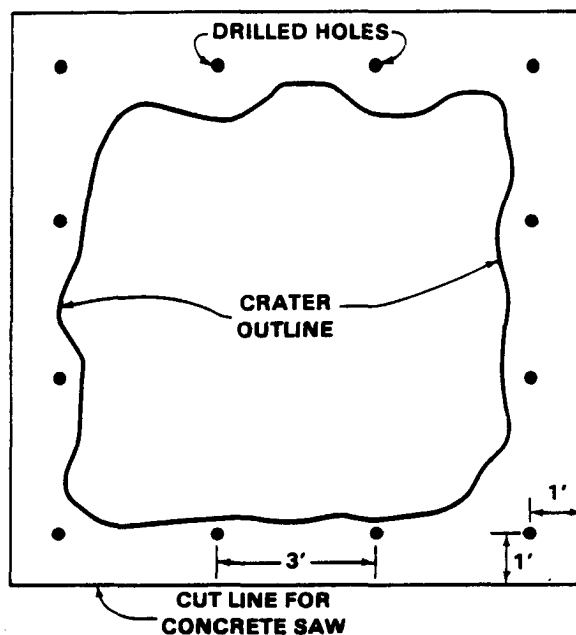
FIGURE A-9. DRILLED HOLES FOR CONCRETE SLAB REPAIR

row of slabs need only be placed as shown in Figure A-8 if the crater diameter exceeds 45 feet. For small-diameter craters, the mechanical screed does not require hand-placed slabs.

- Place precast concrete slabs onto the leveling course using forklifts or bucket loaders with boom sling attachments. Lower the slabs horizontally so that they uniformly bear on the leveling course, thus preventing differential settlement. At this stage the slabs should stand no more than 1 3/4 inches above the level of the surrounding pavement. Use metal spacing bars to ensure a gap of 1/2 inch between the edges of adjacent slabs.
- Settle the slabs into the leveling course gravel by driving the 10-ton roller twice over each slab.
- Conduct a final surface roughness check to ensure that the repaired surface is within specified tolerances. If the specified tolerances are not met, continue to compact the slabs and check for new results. As a last resort, lift up the slabs which have not settled to the required level and remove and/or level the gravel leveling course beneath it.
- Conduct a final sweep around the crater.

For the advantages and disadvantages of crater repair methods, see Table A-3.

TABLE A-3. ADVANTAGES AND DISADVANTAGES

EMERGENCY REPAIR	ADVANTAGES	DISADVANTAGES
CRUSHED STONE	<p>Easy to train Very fast No special equipment Material availability</p>	<p>Compaction is critical Needs FOD cover Maintenance may be frequent due to settlement</p>
FOD COVERS		
FRP	<p>Maximum thickness 3/8 -inch helps achieve surface roughness Not labor intensive Preassembled at air base</p>	<p>Cannot be rolled up for storage Time to drill bolt holes</p>
AM-2	<p>Can be preassembled Load-bearing surface Available in large quantities</p>	<p>Labor intensive Assembly is exhausting Inadequate for cargo jets 1 1/2-inch thickness hinders achieving surface roughness If damaged, panels are difficult to replace</p>
PRECAST CONCRETE SLABS	<p>Easy to maintain Load-bearing capacity</p>	<p>Requires special tools Cutting concrete takes time More difficult to move and level blocks Differential settlement</p>

APPENDIX B

ARMY CRATER REPAIR

Joint service regulation AR 415-30/AFR 93-10 requires the Army to conduct emergency repair of war-damaged air bases where requirements exceed the Air Force's organic repair capability. Since the Army has a contingency mission for performing emergency repair of air bases, Army engineer units must train using Air Force crater repair methods covered in Appendix A. These emergency repair methods are preferred if materials are available.

For rapidly deployable forces and for use on air bases and Army airfields, the Army has developed the sand grid method as an alternate emergency repair solution. Army engineer units, especially light, airmobile, and airborne, should train with the sand grid method since it is easily emplaced and provides an acceptable emergency repaired surface. The sand grid method is lightweight, air transportable, and does not require prestocked supplies of either crushed stone or concrete slabs, which makes it particularly useful to these units.

Additionally, the Army is required to repair and restore air base damage beyond emergency repair. Beyond emergency repairs upgrade Air Force emergency repairs or unrepaired craters and spans, and require the use of materials similar to those of the original construction. For beyond emergency repairs, the Army has developed two techniques. These techniques are a concrete cap and a stone and grout cap.

GENERAL CRATER REPAIR ACTIVITIES

Certain repair procedures are standard for all Army repair methods. Crater preparation consists of preparing both the crater "bowl" and the crater "cap" (see Figure B-1). The bowl consists only of backfilled debris and aggregate. It provides foundational support for the cap. The cap consists of either sand grids overlain by an FOD cover, concrete, or stone and grout. It provides some strength, acts as a sealant against moisture, and restores a suitably smooth runway surface.

FIGURE B-1. CRATER BOWL AND CAP

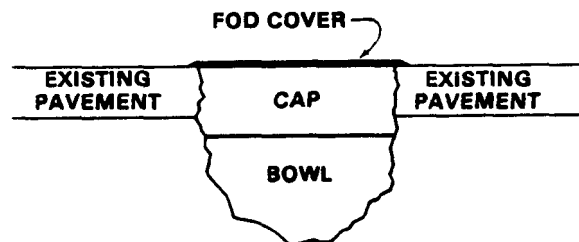

In preparing the bowl, all standing water must be removed from the crater bottom by the most efficient means available. This is necessary to allow for proper compaction of subsequent fill layers and to avoid an excessive settlement of the cap. Pneumatic pumps are ideally suited for water removal.

The debris and small heaved material (no dimension greater than 12 inches) are placed back into the crater, in layers, and compacted to at least 85 percent compactive effort (CE) 55 California Bearing Ratio (CBR) of approximately 4. All oversized, large debris is then pushed away from the site.

Aggregate must be loaded and transported from the quarry/stockpile to the crater site. Improper compaction is most often the cause for crater repair failure. Speed is important, but it is critical to stress compaction quality control.

Throughout the repair operation, the runway must be cleared of all foreign objects and debris which might interfere with the resumption of emergency aircraft operations.

EMERGENCY REPAIR

Sand Grid

The sand grid repair is a rapidly deployable, lightweight, and inexpensive RRR technique. The sand grid, with a cover of FRP mat, is designed to withstand 1,000 sorties of an F4 (or 500 sorties of an F15), 200 sorties of a C141B, and 300 sorties of a C130. The sand grid repair method is performed as follows:

- Backfill the crater with compacted debris not higher than 16 inches below the existing pavement. Place an, impervious membrane on top of the debris. This prevents inflow of the water table into the sand grid. Also, the membrane prevents the sand in the sand grid from filtering into the debris and causing localized failure and short-term differential settlement in the runway surface.
- Place one layer of sand grid on top of the compacted ejects (debris). Use pickets or place sand on the corners and sides to prevent the accordion-like sand grid retracting to its original form. Using a bucket loader, fill in the sand grid from the near end to the far end. Personnel using hand shovels should ensure that each grid is completely filled with sand. Once a sand grid section is filled with sand, it will support the weight of a bucket loader. The bucket loader can then walk on the completed portions of the sand grid and progressively dump sand into unfilled portions of the sand grid.
- Once the entire first layer of sand grid has been filled with sand, place a second layer of sand grid on top of the first layer. Offset the second layer so that the edges of both layers of sand grid do not line up directly (see Figure B-2). Fill the second sand grid using the same procedure as for the first layer. Fill in any low spots by hand.

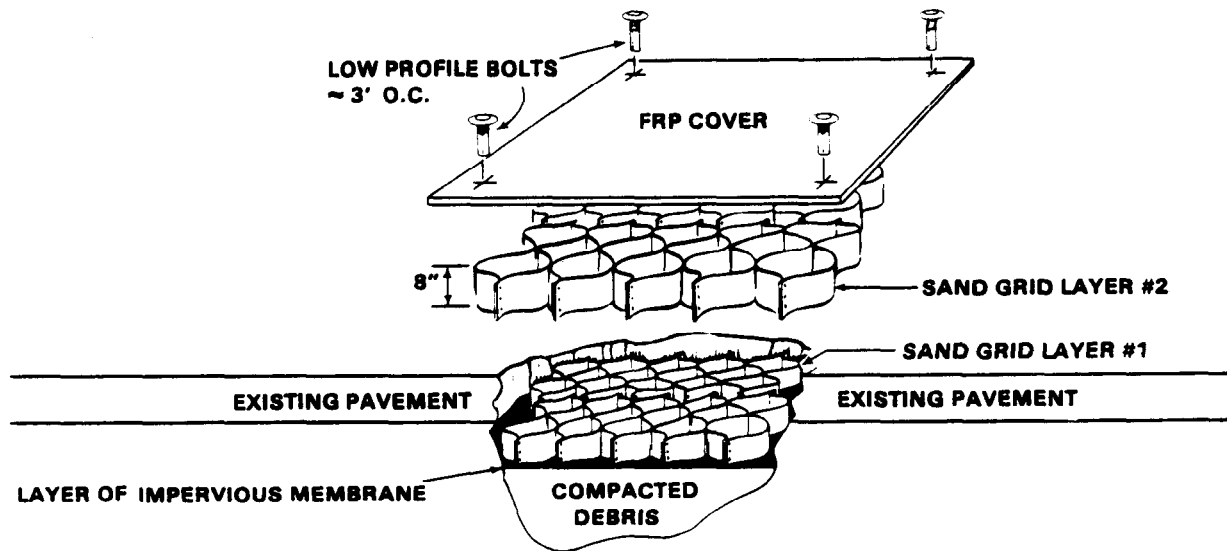
FIGURE B-2. SAND GRID REPAIR

- Place an FRP mat or M-19 matting on top of the repair to prevent FOD.
- For maintenance of the sand grid, use a bucket loader with chains to pick up the edge of the FRP mat or remove the mat entirely so that more sand can be added to the sand grid layers. Replace the FRP mat and secure it to the pavement.

BEYOND EMERGENCY REPAIR

Concrete Cap

Backfill the crater with compacted debris not higher than 28 inches below the existing pavement. Place well-graded crushed aggregate on the compacted debris in lifts having thickness of 12 inches or less. When the surface of the newly placed lift is sufficiently lower than the surrounding pavement, a ramp of the same material might be required for equipment to enter and exit the crater. The lower lift must be compacted to 95 percent CE 55 and the top lift must be compacted to 100 percent CE 55 density. The top lift terminates at least 12 inches below the existing pavement. Compaction effort around the edges must match the compactive effort being made in the crater interior. This is best accomplished using plate compactors and hand-tampers. Improper compaction is most often the cause for repair failure.

For craters smaller than 30 feet in diameter, screeding can generally be performed by hand. When single craters or overlapping craters form a damaged area greater than 30 feet in diameter, a screed method using a concrete pedestal is recommended. It is highly advisable for

Army units to prefabricate concrete pedestals (see Figure B-3). Ask the BCE to include these pedestals in prestocked supplies at the air base.

FIGURE B-3. PEDESTAL DESIGNS

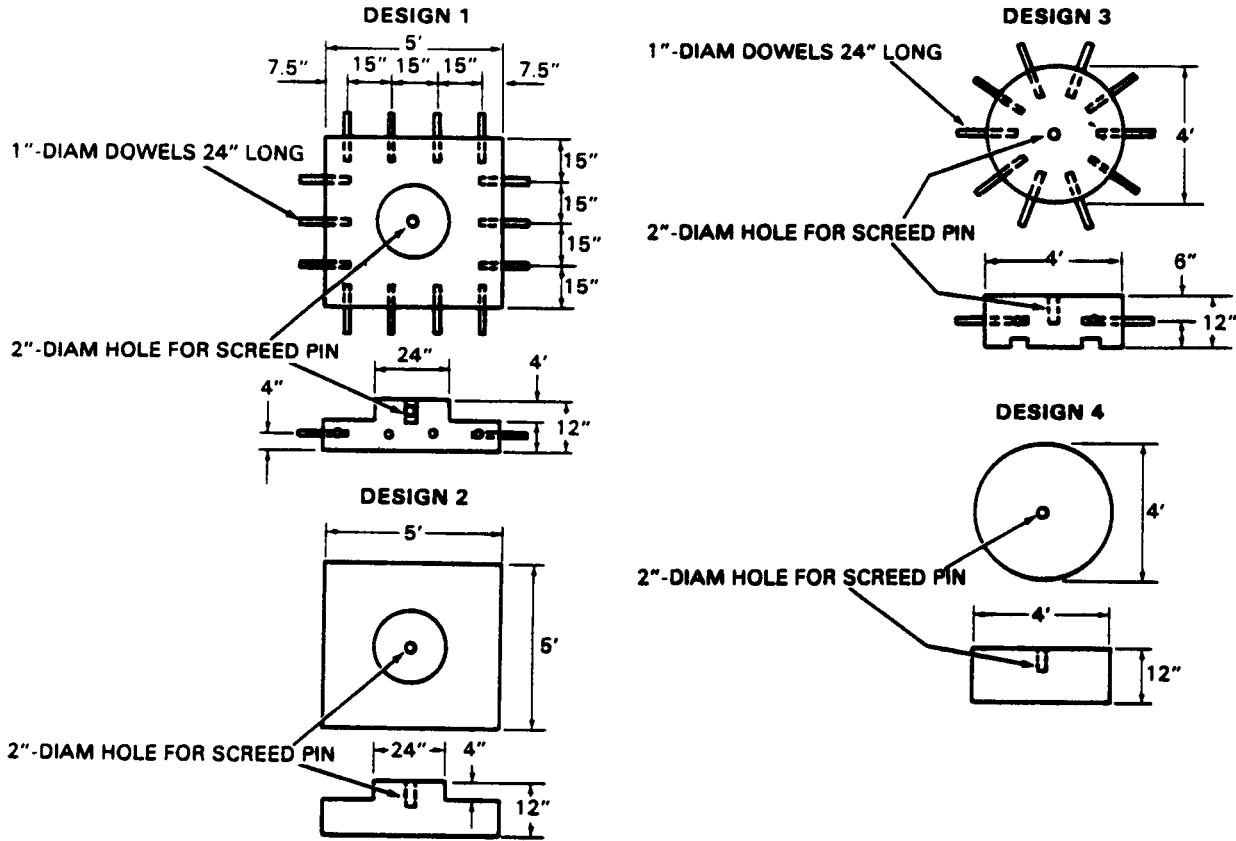

Prepare the center of the crater so that the surface of the prefabricated concrete pedestal is even with the surface of the runway pavement (see Figure B-4). This is best accomplished with a string line.

Secure the screed beam to the pedestal by placing a steel pin through the beam into the slot in the pedestal. Clean the edges of the crater and place a starter form in the crater. The starter form is an artificial headboard form which allows the concrete to be rapidly leveled as it is placed into the crater. The starter form is removed from the crater as soon as the placement is completed. Experience has shown that load transfer devices (such as dowels) are not needed to permit better bonding to the existing runway.

Placement of the 12-inch concrete cap is dependent upon concrete materials for the concrete-mobile trucks or host nation support for ready-mix concrete trucks. Portland cement concrete

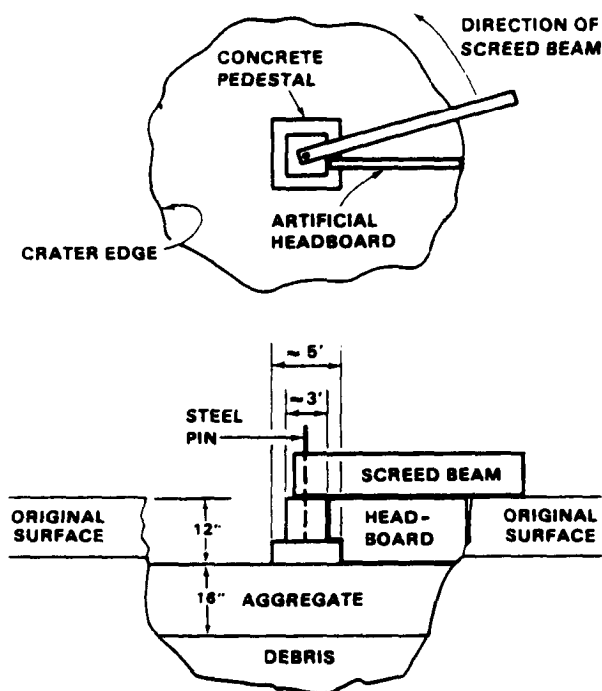
FIGURE B-4. CONCRETE CAP USING PEDESTAL

may be made with either Type I/Normal or Type III/High-Early cement. Whether the concrete is ordered or made on site, the concrete must achieve a compressive strength of at least 1,500 pounds per square inch (psi) within 24 hours.

It is critical to ensure a homogeneous placement of the concrete cap. At least three concrete ready-mix or concrete-mobile trucks should be pre-positioned around the crater to allow an initial steady placement of concrete into the crater. Finish the surface until it is smooth and level with the surrounding pavement (see Figure B-4). An accelerator must be added to quicken the curing time. The concrete must be allowed to cure at least 24 hours before trafficking fighter aircraft.

STONE AND GROUT CAP

Placement at or Above Freezing Temperatures

Backfill the crater with compacted debris not higher than 28 inches below the existing pavement. Place well-graded crushed stone on the compacted debris in lifts with lift thickness not to exceed 12 inches. Compact to 95 percent CE 55. The top lift terminates 16 inches below the existing pavement (see Figure B-5). Compaction effort around the edges must match the compactive effort being made elsewhere (use plate compactors and hand-tampers).

FIGURE B-5. STONE AND GROUT CAP REPAIR

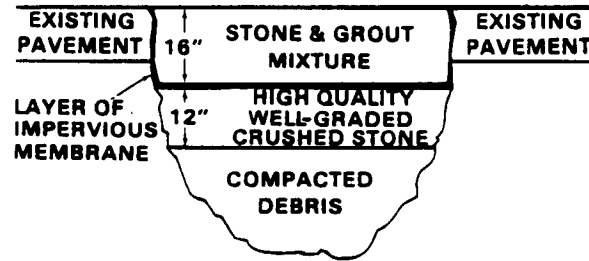

Clean the edges of the crater thoroughly and place a layer of sand approximately 1 foot wide by 1 to 2 inches deep around the entire inside of the crater. This is to prevent seepage of the grout around the edge of the crater.

Place impervious membrane (such as polyethylene, visqueen, or T-17 air base membrane) over the entire gravel surface.

Fill the crater cap approximately 50 percent full with grout. This places the grout at a level about 8 inches below the existing pavement (see Table B-1 for a grout mixture). Ideally, the grout is mixed in a concrete-mobile truck, by hand in the bucket of a bucket loader, using conventional civilian grout equipment, or by other means that will accomplish the mission.

Add the calcium chloride accelerator to the grout mix once the grout has reached the 8-inch level in the crater.

Place 3-inch (56 to 75 millimeters) uniformly-graded stone into the grout until the stone level is even with the existing pavement.

TABLE B-1. STONE AND GROUT MIX PROPORTIONS

GROUT MIXTURE*	PERCENTAGE BY WEIGHT	WEIGHT OF ADDITIVE PER CUBIC YARD
Portland Cement	67.8	2203.2 lb (999.4 kg)
Calcium Chloride (Accelerator)	1	32.67 lb (14.8 kg)
Friction Retarder	0.2	6.68 lb (2.9 kg)
Water	31	1004.4 lb (455.6 kg)

*This mixture will develop at least 1,500 psi compressive strength in 24 hours.

The stone should be worked down through the grout until all stone has been covered with grout and a uniform cross section exists. This is best accomplished by initially walking a bulldozer back and forth across the crater. A vibratory steel wheel roller is then used to compact the grout cap, causing a thin layer of grout to percolate through the stone to top. It is critical to keep the uniformly-graded material free of contamination from fines to ensure good percolation.

The final level of stone and grout should be within 1 inch of the surrounding pavement. Add grout and stone until the surface of the cap matches the level of the existing pavement. No aggregate should extend above the crater surface. The final surface should be finished until smooth and level with existing pavement.

Placement at or Below Freezing Temperatures

Special considerations must be made when placing the stone and grout mixture in freezing temperatures. There are several methods which can be employed to help ensure successful mission accomplishments:

- Add additional calcium chloride accelerator (up to as much as 3 percent by weight from the normal amount of 1 percent) to the solution of stone and grout to decrease the set time.
- Heat the aggregate. This can be done in a tent surrounding aggregate stockpiles.
- Heat the water. One possible method is to use immersion heaters. It is best to heat both the water and the aggregate, rather than just one. This helps ensure that the extremely cold condition of either component will not offset the heated condition of the other. Do not mix the water and aggregate until the last possible moment.
- Do not uncover the subgrade until immediately before placement to allow heat to be retained. This necessitates a change in repair priorities since several craters cannot be worked on concurrently (as their subgrades would be left exposed while awaiting grout). Rather, one crater is completely repaired before moving on to repair the next.
- Place an insulated blanket over the finished concrete surface. One possible composition of this blanket is a layer of impervious membrane, approximately 10 inches of straw or hay, followed by an additional layer of impervious membrane.

SUMMARY

While the concrete or the stone and grout cap repair methods may be employed to conduct beyond emergency repair, one may be more feasible than the other due, to availability of materials. For example, the concrete cap method greatly depends upon the availability of host nation support. The stone and grout repair method is less dependent upon host nation support, since it requires materials often available to engineer units in times of conflict. The advantages and disadvantages of emergency repair and beyond emergency repair methods are shown in Table B-2 on page B-8.

TABLE B-2. ADVANTAGES AND DISADVANTAGES

		ADVANTAGES	DISADVANTAGES
EMERGENCY REPAIR	SAND GRID	Simple Low cost Lightweight Little storage space required Air transportable	Frequent maintenance Needs suitable filler material Requires FOD cover
	STONE AND GROUT CAP	Material availability Applicable for troop on-site mixing	Requires the largest number of troop man-hours and equipment hours
BEYOND EMERGENCY REPAIR	HIGH/EARLY CONCRETE CAP (TYPE III)	Smooth finish Easy placement Maintenance free	Poor results in freezing weather Needs pedestal Host nation support needed
	TYPE I/NORMAL CONCRETE CAP	Readily available and familiar Not as expensive as High/Early concrete Smooth finish Maintenance free	Poor results in freezing weather Needs pedestal Host nation support needed

While several other concrete types (such as Reg-Set concrete) have been tested for crater repair, the methods listed in this appendix are the only acceptable beyond emergency repair solutions.

APPENDIX C

ARMY AND AIR FORCE SPALL REPAIR

Repair of spans can be achieved in a number of different ways. All involve a refilling of the damaged area with a type of concrete or concrete substitute. Both concrete runways and concrete runways over-laid with asphalt are repaired in the same manner; only one substance is used to repair the span. For example, asphalt is not placed onto the surface of the span filler simply to conform with the existing pavement. Spalls may be repaired using concrete stone and grout mixture, and polymer concrete. Experience and testing to date have primarily been conducted with a polymer concrete product known as Silikal. While other products may perform as well, they have not yet been extensively tested. A type of polyurethane, polymer cement is being developed by the Air Force as a possible substitute for Silikal, but has not yet been fielded. Where more than one repair technique is possible, the type of repair used should be dictated by such factors as material availability, soldier expertise, repair time required, and durability of repairs.

CONCRETE AND STONE AND GROUT

The use of these materials for the purpose of placing caps has been discussed previously in this training circular. For use in spall repair, the placement procedures are essentially the same. No impervious membranes are placed in the spall since the damage does not penetrate the pavement and water fluctuations are of no concern. Additionally, the stone and grout method may need to be modified to allow for the decreased depth of the damaged area.

This involves the mixing of smaller rock (pea gravel) with the grout to ensure a smooth surface. Regardless of the type of material used, sufficient amounts must be available to fill the entire spall at one time. Filling a span too slowly (allowing portions placed to set before additional amounts are added) reduces the strength and durability of the repair.

SILIKAL

Silikal polymer concrete is the presently recommended span repair material. It is the most easily prepared and the fastest setting of the materials previously discussed. Both the Air Force and the Army have adopted it as the preferred method for repairing spalls. Two types of Silikal are used commercially for repairing concrete-R7 gives high strength and R17 gives low shrinkage. Both take three to four hours to set and can only be cured at temperatures above 40 F. Therefore, they are not normally suitable for span repair. However, rapid setting versions have been developed for the German Air Force (those are called R7/Bw and R17/Bw; Bw for "Bundeswehr"). They can be cured at temperatures down to 0°F and are suitable for spall repair.

Silikal is a methyl methacrylate polymer mortar comprised of powder resin, liquid hardener, and catalyst components. The resin and hardener are mixed in the proportion 7.5 to 1 to produce a

pourable mixture. It is possible to add pea gravel, up to the same weight as that of the powder component, to extend the mortar. Skin begins to form on the surface of the Silikal 5 to 10 minutes after mixing, and after 30 to 60 minutes it is sufficiently cured to support aircraft traffic.

MATERIAL PROPERTIES

The liquid component is highly flammable and, because it dissolves bitumen, damages asphalt surfaces. The cold-temperature accelerator, contained in a compartment in the base of the can of liquid component, is toxic. Fumes produced by the mixing of Silikal components are also toxic. Empty cans containing accelerator should be disposed of as toxic waste. This accelerator should only be used at and below the freezing point (32°F). At higher temperatures, it reduces the strength of the cured mortar. Silikal is highly moisture-sensitive. Ideally, only dry pea gravel should be used to "bulk" (extend) the Silikal, and the span should be as dry as possible before Silikal is poured into it. However, when Silikal is poured into water-filled spans it displaces the water and the span repair is successful. This is probably due to mechanical interlock with the sides of the hole rather than material bonding.

PACKAGING

One package of Silikal R7/Bw contains--

- One 33-pound bag of powder component.
- One can of liquid, containing .5 gallon of hardener and, in a false bottom, 3.3 fluid ounces of accelerator.
- One white paper bag containing 5.2 grams of powdered benzoyl peroxide initiator (catalyst) at half strength.
- One polyethylene mixing bag 26 inches by 27 inches.
- The shelf life is five years, provided the temperature never exceeds 77°F.

MIXING AND PLACING PROCEDURE

- Remove loose debris and unsound pavement from the span hole. An air compressor is ideally suited for this task. Lumps of concrete are a good bulk filler for deep spans.
- If the hole is smooth, dish-shaped, and wet, it is desirable to form 1-inch deep holes in the sides to reduce the likelihood of the repair popping out of the hole under aircraft loading.
- If the hole is wet, try to remove free water and, if possible, dry the hole with heat or compressed air.
- Pour the powder component into the polyethylene mixing bag.

- Tear open the white bag and pour the benzoyl peroxide initiator into the mixing bag. Mix the two powder components together before adding the liquid.
- At temperatures above freezing, open the liquid hardener can at the top and pour the liquid into the mixing bag. At temperatures below freezing, open the can at the bottom (marked with a blue strip and a picture of silver ice crystals) and puncture the membrane between the accelerator and the hardener with a spike or a screwdriver. Pour the hardener and accelerator through the bottom of the can into the mixing bag.
- Close the mixing bag by holding the top corners and twisting, leaving only a small air space above the surface of the mortar. Holding the bag closed with one hand, grasp a bottom corner and knead and roll the contents for one to two minutes, or until a uniform mixture is achieved.
- If the spall is at least 2 inches deep, up to 33 pounds of dry pea gravel can be added to the Silikal in the mixing bag and mixed for an additional 30 seconds. This acts as an extender to the amount of Silikal produced.
- The mixing bag is held over the spall and split open with a trowel. The Silikal should pour out like a fluid (if it does not, there is either too much aggregate or the Silikal has begun to set because of too much benzoyl peroxide) and should not be allowed to fall through a distance greater than 1 foot.
- The Silikal is then tamped into the spall and leveled off with a trowel. It remains workable for 5 to 10 minutes.

CLEAN UP

Tools should be cleaned before the Silikal sets on them, using as a solvent the liquid hardener, acetone, methylene chloride, or trichloroethylene. At temperatures above freezing, the empty Silikal cans will contain the cold-weather accelerator and must be disposed of as toxic waste.

SAFETY PRECAUTIONS

Span repair personnel should roll down their sleeves and wear chemical resistant gloves and safety goggles. If the liquid component splashes onto the skin, it should be washed off immediately with water. Do not swallow the liquid component or breathe in its vapors over an extended period. Since the fumes are hazardous, personnel placing Silikal may need to don the protective mask if exposure to the fumes will be extensive. Keep sparks and flames away from the highly flammable liquid component.

APPENDIX D

ASSEMBLY AND FABRICATION OF POLYURETHANE IMPREGNATED FIBERGLASS MATS AND AM-2 MATTING

This section outlines the procedures for fabricating polyurethane impregnated fiberglass mats (PFM) and assembly of AM-2 matting for rapid repair of bomb-damaged runways. Mats are fabricated in advance and/or stored until used with the crushed stone crater repair method (Appendix A). Equipment and materials, safety procedures, and techniques for the operation are covered in detail.

BACKGROUND

Crater repair, using a crushed stone base course covered with a PFM, has been developed as a less expensive, more expedient alternative to the AM-2 mat. Fiberglass mats impregnated with both polyester and polyurethane resins were investigated in the developmental test and evaluation (DT&E) program. Based on the results, PFMs have been recommended for use. The polyurethane resin system was judged to be safer, simpler, more structurally sound, and less expensive than the polyester resin system used for fiberglass-reinforced polyester (FRP) mats.

The performance of various thicknesses of fiberglass mats in laboratory and field testing indicates that a two-ply mat is required for strength. The edges of the mats are reinforced with an additional ply of fiberglass to accommodate an anchoring system recessed into the mat to minimize damage from aircraft tailhooks. A 50-foot by 60-foot mat can be selected for fabrication, based on the width of the MOS, for postattack repair and expected bomb crater diameters. However, smaller mats can be made if the threat indicates smaller craters are in order. The 50-foot by 60-foot mat can be cut to make two 50-foot by 30-foot or two 25-foot by 30-foot mats.

Smoothness and uniform impregnation are two major quality control issues in the fabrication process affecting the performance of the mat. Minor wrinkles or surface irregularities result in earlier damage due to both high wheel loads and tailhooks. Therefore, smoothness of the PFM is a requisite. Uniform penetration of polyurethane resin is required to produce optimum strength. Pooling of resin will increase mat cost, may make the mat brittle, and can cause mat failure.

PROCEDURES

- **Safety Procedures.** Upon arrival at the work area, personnel don protective gear--coveralls, gloves, overshoe boots, spatterproof goggles, and respirators. Check proper fit and condition making sure that goggles and respirators are sealed against the face. Brief personnel once more on the use, maintenance, and disposal of safety gear. The use of emergency eye wash stations should be demonstrated. Warning signs for overexposure symptoms and workplace practices must be posted prominently. During the fabrication process, remind personnel of the proper handling and safety procedures.

- Site Preparation. An ideal fabrication area is a smooth, level, paved surface: for example, a hangar floor. The area should be clean, cracks in the surface filled, and all raised joint seal removed. Clay, if available, or fine sand work well to fill cracks.
- If a sufficiently smooth paved area is not available, mats can be fabricated on a plywood platform. The platform should be maintained with as smooth a surface as possible. Warped or scarred sections should be replaced promptly.
- To prevent the mat from adhering to the work area, a bondbreaker is placed on the work surface. Typical bondbreaker materials are plastic polyethylene or mylar sheeting. A transparent bondbreaker is recommended because it allows visibility of mat dimension boundaries painted on the floor. Adjoining strips of plastic should overlap at least 18 to 24 inches, and should extend 4 to 5 feet beyond the intended edge of the mat. The bondbreaker should be placed smoothly to prevent formation of ripples in the fiberglass. The bondbreaker sheets can be stapled to the sides of a fabrication platform. If a paved area is used for fabrication, depressions should be filled and joints trimmed smooth prior to bondbreaker placement.
- Sealed drums of the polyurethane components, fiberglass, and solvent sufficient for the day's operation are brought to the fabrication site. For a 50-foot by 60-foot mat, six drums each of resin component are required. Extra drums (for one to two mats) should be stored in the fabrication area to allow drum temperature to adjust to the working area ambient temperature. The required equipment for handling fiberglass, applying resin, and finishing mats should be readily available on site.
- Fabrication should be conducted in a covered, ventilated area whenever possible. A ventilated, covered area provides engineering controls to maintain a safe work environment, with isocyanate vapors below established threshold limit values (TLV).
- A covered area also provides protection from the elements, necessary for best results during polyurethane impregnation. The covered area must be leakproof with adequate drainage around the building to keep mats dry during inclement weather. Absorbed moisture in wet fiberglass will react with the isocyanate components in polyurethane, producing carbon dioxide. The carbon dioxide bubbles result in a weak, spongy finished product. If mats must be fabricated outside, weather delays should be expected. Fabrication of large mats should be started only when rain is not anticipated before the mat is finished.
- Fiberglass Layout. The mats are generally fabricated as ready-to-use, full-size mats, with finished dimensions of up to 50 feet by 60 feet. These dimensions are based on expected crater dimensions and MOS geometry but can be varied, based on expected air base threat.

OVERVIEW

Polyurethane impregnated fiberglass mats are constructed by placing several layers of fiberglass on a prepared fabrication site, mixing buckets of polyurethane resin components, and pouring the resins onto the fiberglass (impregnating the fiberglass). After the polyurethane has hardened, mats are trimmed to finished dimensions and anchoring holes are cut along the edges.

Fiberglass woven by two vendors and two polyurethane resin systems have been approved for use. Resin is mixed and poured in buckets, and worked into the fiberglass by squeegees. Saws, drills, and routers are used in making PFM ready for crater repair.

A fiberglass mat fabrication team usually consists of ten people. Two groups of four unroll and smooth each strip of fiberglass, and two other individuals pre-cut strips which are less than full width, measure the mat, and ensure adequate fiberglass layer overlap. The team then works to impregnate the fiberglass with resin. One person dispenses and measures the resin, one person pours the resin onto the fiberglass, and three people work the resin by using squeegees.

MATERIALS, TOOLS, AND EQUIPMENT

The materials required for PFM fabrication are fiberglass and polyurethane resin. Storage conditions are listed in Table D-1. The fiberglass used is a 4020-weight weave, each ply consisting of 40 oz/yd² of woven roving chemically bonded to 2oz/ft² of chopped strand. The fiberglass conforms to Military Specification MIL-C-19663C. Two vendors have been identified and approved as fiberglass suppliers.

Two polyurethane resin systems have been accepted for fiberglass mat fabrication. One system, produced by Ashland Chemical Company, consists of Resin 65-17 (a polyol blend), Resin B65-12 (isocyanate), and Catalyst 65-18. These components are brown viscous liquids, forming a yellow or light brown product when set. An alternate system is PERCOL resin manufactured by ARNCO, which is pre-catalyzed and has a red isocyanate component and a blue polyol component, reacting to form a green polyurethane mat when set. For cleanup, 1,1,1 trichloroethane is the recommended solvent. Absorbent material should also be available to clean up small spills. Overpack drums are used to salvage leaking drums.

TABLE D-1. STORAGE CONDITIONS

<u>Material</u>	<u>Storage</u>
Fiberglass	Off-ground, dry In waterproof, opaque wrap
Polyurethane Resins (Resin Drum Pallets)	Store in cool and dry area. Separate by 6" to 8". Keep out of direct sunlight. Handle as combustible material. Use a forklift with caution. Do not damage drums.
Catalyst	Separate from other chemicals. Cool, dry storage and static grounding required.

FABRICATION AND PLACEMENT CONSIDERATIONS

Anchor System Requirements.

- For concrete pavements, 5-inch long by 5/8-inch diameter Wej-It or similar rock bolts are used. Be sure to use the correct size drill bit when placing any rock bolt, as the wedge cannot grip and then expand in an oversized hole. Drilling is a two-stage process; a 1 1/2-inch diameter, 1/2-inch deep recess, must also be drilled into the pavement to take the stem of the bushing.
- For asphalt overlaid concrete pavements (usually about 2 to 5 inches of asphalt over an 8-inch thick concrete slab), use longer 5/8-inch diameter Wej-It or similar rock bolts. The rock bolts must be long enough to allow the whole length of the wedge portion of the bolt to be imbedded to grip the concrete.
- For asphalt pavements, without any concrete, use a 5-inch long, 5/8-inch diameter bolt with wings or flattened edges to resist rotation (Wej-It bolt with wedges removed). Use a 1 1/2- to 2 1/2-inch diametermoil point and jackhammer to make holes in the asphalt. Mix and pour polyurethane, or other rapid-setting polymer material, into each hole so that when the bolt is inserted, the polyurethane level is just below the underside of the countersunk bushing. Screw the bushing onto the top of the bolt, and then put the bolt into the polyurethane-filled hole and hold it down with your foot until the polyurethane has set. The catalyst in the polyurethane should be sufficient to allow a set time of one minute. Finally, tighten the bushing down with the spanner wrench.
- Seventy-five bushings are enough for a mat to be cut and installed as four 25-foot by 30-foot mats or as a single 50-foot by 60-foot mat bolted on all four sides. Forty bushings are sufficient to anchor a 30-foot by 30-foot mat on all four sides.

Drills.

- Use pneumatic drills for drilling holes in concrete and asphalt-overlaid concrete. Pneumatic drills work well in concrete, but are slower in asphalt.
- Electric drills may be used for both concrete and asphalt, but are slower in both cases. Electric drills, if in poor repair, may be a safety hazard in wet weather.

Tailhook operations over fiberglass mats

- When PFM crater repairs are used on parts of the runway over which aircraft tailhooks are to be dragged, special precautions must be taken to ensure that the tailhook does not get underneath the mat cover and tear it up. After the PFM has been bolted to the runway, a 6-to 9-inch wide ramp made of a mixture of sand and polyurethane should be formed on the runway surface along the leading edge of the mat. If the runway is wet, a series of 1-inch diameter holes, 2 inches deep and at 1-foot centers should be drilled along the line of the ramps before the polyurethane and sand is placed. This improves the bond to the pavement surface. This ramp will make the tailhook move up from the level of the runway surface to the top surface of the mat. A horizontal gap of 1 inch should be left between the

edges of the mat and the ramp to allow the mat to be removed and replaced when maintenance on the crater repair is required.

SAFETY

Because fabrication of PFMs involves handling hazardous materials and potentially dangerous equipment in an industrial environment, safety considerations must be given major emphasis. Of special importance are the issues of material handling safety, waste disposal, and industrial safety.

MATERIAL HAZARDS

Fiberglass

The greatest hazard from fiberglass is the potential irritation of the respiratory tract from the inhalation of dust and fiber particles. Each ply of 4020-weight fiberglass has a chopped strand layer chemically bonded to a woven roving layer. The chopped fibers can become loose during handling and, when combined with the small fibers and dust released when impregnated fiberglass is cut, constitute a potential health risk in the workplace environment. Dust is a major problem when trimming and finishing impregnated mats. Fiberglass can also irritate the skin, causing itching, redness, and rash-like patches.

Polyurethane

The polyurethane resin system consists of two components, isocyanate and polyol, and a catalyst which is added to the polyol. The catalyst is either premixed by the resin supplier or must be added by the user before mixing the polyol component with the isocyanate component to polymerize the resin. Polyurethane have differing physical properties. Both resins validated for use in PFM fabrication are combustible, but one resin, PERCOL™, has a significantly higher flash point. PERCOL™ is also less viscous than the Ashland Resin System. The solvents for processing these two resins differ - one resin is in an aromatic solvent, and the other is in a chlorinated solvent. The manufacturer's labeling of the two components also varies - Ashland Chemical refers to the isocyanate side as the "B" component (Ashland Resin B65-12), while ARNCO labels it as PERCOL™ "A" side.

The polyurethane isocyanate component is a polymeric diphenyl-methane diisocyanate (MDD), dissolved in either a chlorinated or aromatic solvent. It is classified as a hazardous material with a TLV of 0.02 parts per million (ppm) (0.2mg/m³) established by the Occupational Safety and Health Administration (OSHA). According to the American Conference of Government Industrial Hygienists (ACGIH) the TLV represents the conditions under which it is believed that workers may daily and repeatedly be exposed to a material without adverse effects based on a 5 day, 40-hour work week. The TLV for MDD, however, is a maximum value not to be exceeded. The polyol component contains trace amounts of hazardous organometallic catalysts, shipped mixed in a chlorinated or aromatic solvent and must be treated as a hazardous material. No TLV has been established for polyol.

Polyurethane can be irritating to the skin and eyes. The isocyanates may, in some instances, react with skin protein and tissue moisture causing reddening, swelling, and blistering. When isocyanates contact eye fluid, the reaction causes dehydration and resulting discomfort, vision blurriness, and possible temporary partial vision loss (similar to the loss experienced by cataract patients). While there is little data on the effects of polyol contact with skin and eyes, contact should be avoided.

The major potential health hazard associated with these resins is irritation of the mucous membrane in the respiratory tract, resulting from overexposure to isocyanate vapors. Symptoms of overexposure are tightness of chest, labored breathing, breathlessness, and nasal irritation, at times accompanied by nausea, dizziness, headache, and fatigue.

Toxic fume detection test samples were gathered by base bioenvironmental engineering personnel during fabrication efforts at Tyndall Air Force Base, Florida, and analyzed by occupational and environmental health laboratory personnel at Brooks Air Force Base, Texas. Results indicated levels of MDD higher than the TLV during fabrication operations when spray equipment was used, but no MDD vapors were detected during manual bucket mixing and pouring operations.

Even with evidence of low vapor concentrations, a slight possibility of respiratory discomfort exists for fabrication personnel. Studies have shown that a small percentage of the population can become sensitized to MDD vapors at very low concentrations, experiencing discomfort or other overexposure symptoms. Anyone suffering from these symptoms should be immediately removed from the work area and should have a fresh air supply administered. Medical personnel should be notified.

Solvent

The recommended solvent for mat fabrication is 1,1,1 trichloroethane (methyl chloroform). A TLV of 350 parts per million (ppm) has been established for this solvent. It can cause severe eye irritation, gastrointestinal irritation, and moderate skin irritation from prolonged or repeated contact. Excessive vapor inhalation can cause nasal and respiratory irritation, dizziness, weakness, fatigue, unconsciousness, or asphyxiation.

Persons affected by 1,1,1 trichloroethane vapors should be removed from the work area to fresh air. If breathing is labored, medical attention must be provided. Ingestion of the solvent requires immediate treatment by a physician.

RECOMMENDED HANDLING PRACTICES

Personnel Practices

The warning sign shown in Figure D-1 should be posted prominently in the work area to alert personnel of potential health hazards. Recommended practices (Figure D-2) should also be posted in the work area.

FIGURE D-1. ISOCYANATE SENSITIVITY (RESPIRATORY TRACT IRRITATION)

REPORT ANY DISCOMFORT OR SYMPTOMS IMMEDIATELY!

- SYMPTOMS
 - TIGHTNESS OF CHEST
 - NASAL IRRITATION
 - LABORED BREATHING
 - BREATHLESSNESS
 - DIZZINESS
 - WEAKNESS
 - FATIGUE
 - NAUSEA
 - HEADACHE
- FIRST AID
 - REMOVE AFFECTED PERSON FROM WORK AREA
 - ADMINISTER FRESH AIR SUPPLY
 - NOTIFY MEDICAL AUTHORITIES

FIGURE D-2. MATERIAL HANDLING SAFETY WARNING

- WEAR PROTECTIVE GEAR AT ALL TIMES.
- NO SMOKING, EATING, OR DRINKING IN WORK AREA.
- REPORT ANY SYMPTOMS OF OVEREXPOSURE.
- CLEAN UP SPILLS WITH ABSORBENT MATERIAL.
- REPORT ANY SPILLS WHICH COULD HAVE ENTERED A WATER SUPPLY.
- FOLLOW PRESCRIBED WASTE DISPOSAL PROCEDURES.

Based on the results from vapor monitoring conducted by bioenvironmental engineering personnel, workplace vapor concentrations of MDD are expected to be well below the established TLV using the manual pouring fabrication method. At vapor levels less than the action level (AL, equal to half the TLV) of 0.01 ppm, no respiratory protection is required. However, to allow for differences in workplace environment and ventilation conditions, respiratory protection should be used at all times. Respirator use protects against 0.2 ppm free isocyanate, and is strongly recommended to protect the respiratory tract during fabrication operations.

Personnel working with solvents should wear eye protection and respirators. Respirators should also be worn for protection from organic vapors while working with the elastomeric polyurethane for the hinges on foldable mats, when thinned with methyl ethyl ketone (MEK) and acetone.

Splashproof goggles, coveralls, boots, and chemical-resistant gloves must be worn to protect skin and eyes. Complete gear must be worn throughout the fabrication procedure, including mat finishing and cleanup. Use leather gloves for mat layout, finishing, and clean-up. Rubber gloves are too slick and create a slip hazard. Masking tape works well to seal boots and gloves to coveralls. Gear should be replaced immediately if no longer functional or if it is contaminated. Coveralls should be laundered when soiled. Respirators, in particular, should be checked often and discarded if any of the following conditions are encountered:

- Does not seal properly against the face.
- Becomes wet.
- Solvent vapors are detected when worn.
- Inside surface has a visible coating of dust.

Small amount of polyurethane components spilled on the skin should be wiped off with soft cloths or paper towels. Rubbing alcohol is applied to the affected area, followed by thorough washing. Any marked reddening or irritation of the skin after thorough cleaning should be examined by medical personnel.

Isocyanates will irritate the throat and stomach lining if swallowed. Vomiting should be induced if resins are ingested, and medical assistance should be obtained immediately.

Fabrication personnel should be briefed on hazards, symptoms, appropriate material handling practices, and the proper use of safety gear. Warning signs (Figures D-1 and D-2) should be posted in the work area and workers instructed to observe required precautions, to follow good housekeeping procedures, and to promptly report any undue exposure or spills to supervisors.

Workplace Practices

Eye-wash stations must be maintained near the work area. All mixing, preparation, and application of polyurethanes must be done in a well-ventilated area. All dust and spills must be promptly cleaned up.

Isocyanates will burn in fires or when exposed to heat sources sufficient to cause evaporation of the liquid resin, and can also react violently with moisture or strong bases in a closed container. These components must therefore be protected from excessive heat or contamination with water, alkali, strong bases, or atmospheric moisture. No smoking, open flames, or potential ignition sources should be permitted in areas where isocyanates are stored or used. Drums of polyurethane components should be stored in closed containers as shipped. For safety, maintain temperatures in the storage area between 100°F and 95°F.

The reaction between isocyanates and moisture can cause pressure buildup in closed drums. Eye, face, and respiratory protection should be donned prior to opening drums. The bung should be unscrewed slowly, venting any pressure before fully opening the drum.

If a drum is found leaking, respiratory and eye protection should be donned before the drum is repositioned to prevent further leaking. Contents should be transferred to a clean drum and removed to a safe place.

Absorbent material should be used to clean up small spills and shoveled into an open-top drum for disposal. Large spills should be contained and reported to authorities responsible for cleanup of chemical spills (bioenvironmental engineering, BCE, and fire department). When an emergency response team is required, authorities should be provided identification of these materials in advance so they can be prepared to use appropriate measures to cope with the existing contingency.

Sufficient quantities of 1,1,1 trichloroethane solvent should be kept on hand to clean spills on soiled equipment.

INDUSTRIAL SAFETY

As with any occupational situation, care must also be exercised while handling industrial tools. The PFM fabrication and packaging calls for the use of various shop tools requiring electric power or compressed air. Customary caution is expected in handling these tools and associated power source.

FIRE FIGHTING

Fire fighting personnel must be notified immediately in the event of fire or explosion. The specific materials and chemicals involved must be reported to ensure the emergency team responds with appropriate protection and fire fighting equipment. The toxic by-products from combustion of these chemicals require the use of a self-contained breathing apparatus with full facepiece operated in pressure-demand or other positive pressure modes. Foam, water fog, carbon dioxide, or dry chemical should be used to extinguish flames. Use of water for extinguishing can cause frothing with polyurethane components. This frothing can be violent and life-endangering, especially if water is sprayed into containers of hot, burning liquid.

Polyurethane vapors are heavier than air and can travel along the ground or be moved by ventilation. These vapors can be ignited by heat, pilot lights, flames, or other ignition sources at points far away from the material handling site. Welding or cutting torches on or near empty drums can also present a fire or explosion hazard from residual vapors.

EMERGENCY AND TECHNICAL CONTACTS

For additional information or technical guidance, contact the following agencies:

- Emergency Response (Spill information/Disposal)
Coast Guard Marine Safety Office
Honolulu, Hawaii
Phone: 1-808-546-7146
- Department of Defense Regional Response Team
Phone: 1-808-477-6894
- Hazardous Materials Technical Center
Defense Logistics Agency
Environmental Hygiene
Phone: 1-800-638-8958

Note: These emergency numbers are primarily for the United States and US territories, but can probably provide good technical advice should the need arise overseas if equivalent emergency numbers are not available. Questions on legal or regulatory matters should be answered locally since answers will vary widely, depending on the country.

Manufacturers

- Ashland Chemical Company
Division of Ashland Oil, Inc.
Foundry Products Division
P.O. Box 2219
Columbus, OH 43216
Phone: 614-889-3134
- ARNCO
5141 Firestone Place
Southgate, CA 90280
Phone: 213-567-1378
- Rapid Runway Repair Program Office
HQ AFESC/RDCR
Tyndall AFB, FL 32403
AUTOVON 970-6320
Commercial: 904-283-6320

AM-2 MAT ASSEMBLY SEQUENCE

The RRR team members must make sure that all tools and the matting are loaded onto the low-boy to permit the most efficient off-loading and assembly of the AM-2 matting. The AM-2 mat-

ting must be assembled while the crater is being repaired. Following are the steps involved in assembling the AM-2 matting:

Select the Assembly Area

Early in the repair cycle, the OIC or NCOIC should identify the patch assembly area. The area chosen should be undamaged, preferably on the runway, either to the side of the crater (Figure D-3, Method A) or to the top or bottom of the crater (Figure D-4, Method B). Selected assembly area should allow for a straight, single direction (either parallel or perpendicular to the runway centerline) short pull of the assembled matting. Areas must be cleared of all debris before the matting is assembled. Areas should be swept with the towed sweeper to remove small ejects. Removal of small ejects keeps debris from accumulating in the matting grooves.

FIGURE D-3. PATCH ASSEMBLY - METHOD A

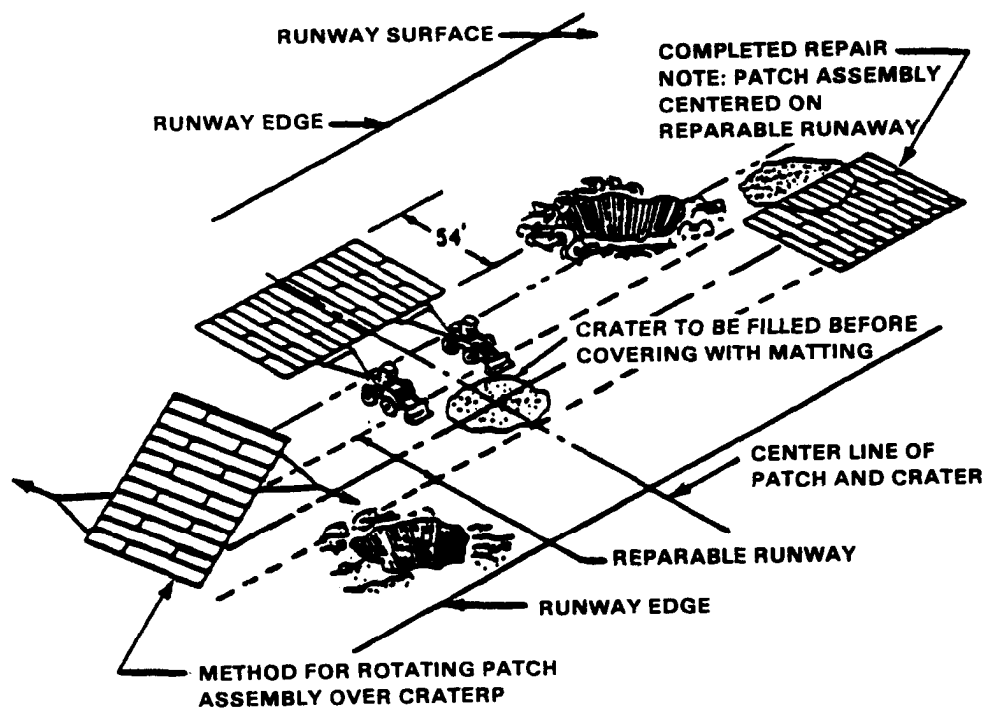
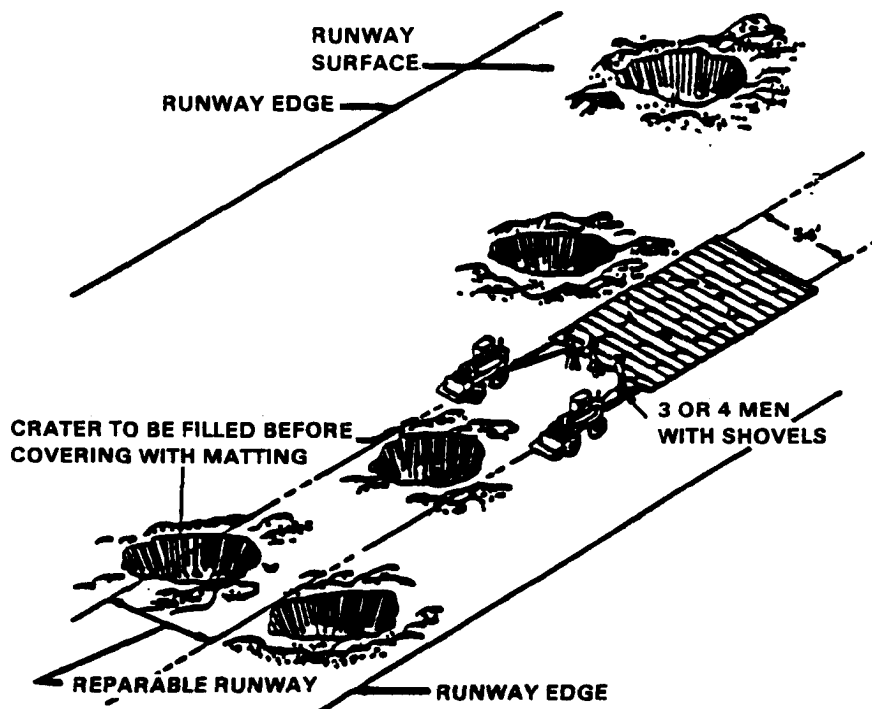

FIGURE D-4. PATCH ASSEMBLY - METHOD B



Assemble the Keylock

Assemble and place male-male keylock at the approximate extended centerline of the crater, either parallel or perpendicular to the MOS centerline. Assembled keylock is 54 feet long.

Assemble the Towing Tubes

The towing tubes on the assembled patch serve two purposes. First, by attaching the proper towing harness, the assembled patch can be pulled sideways to properly align the patch. Second, by attaching the towing tubes on both sides of the patch, the assembled matting is totally locked together and will not separate to "stair step" during positioning or continued use. Fifteen rows of matting (30 feet) are placed on one side of the keylock and 20 rows of matting (40 feet) are placed on the remaining side (Figure D-5). There are various methods of attaching the towing tubes to the matting.

Attaching Towing Tubes

Method A. Concurrent with the keylock assembly, preassemble towing tubes, mandrel, connector fittings, stops, and end caps. (Do not tighten the end caps.) Towing tubes should be assembled perpendicular to the keylock assembly (Figure D-6) and are required on both sides of

the assembled matting. The assembled keylock and towing tubes, prior to the placement of the matting, will resemble the shape of a capital "H."

- Initially, two starter towing tubes are placed on a 20-foot piece of assembled mandrel, centered on the special connector fitting next to both ends of the keylock. (Note: Starter towing tubes are 1 inch longer than the normal towing tubes and do not have a hole for connecting towing clamps. Recommend these tubes, four each per patch kit, be identified and painted a distinctive color to readily differentiate from normal towing tubes.)
- The starter tube that receives the first piece of matting placed on the keylock must be placed on the mandrel with the prongs facing up. The starter tube that receives the last piece of matting from the first row must be placed on the mandrel with prongs up also, but will be rotated to prongs down when attached to the matting (Figure D-6).

FIGURE D-5. ATTACHMENT OF TOWING TUBES

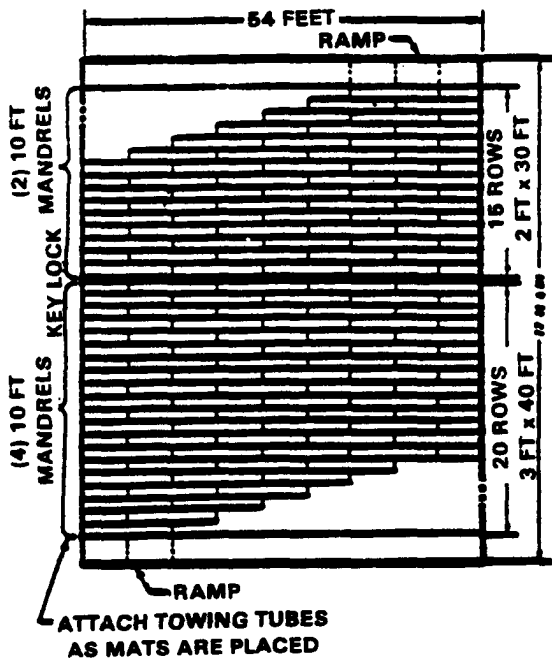
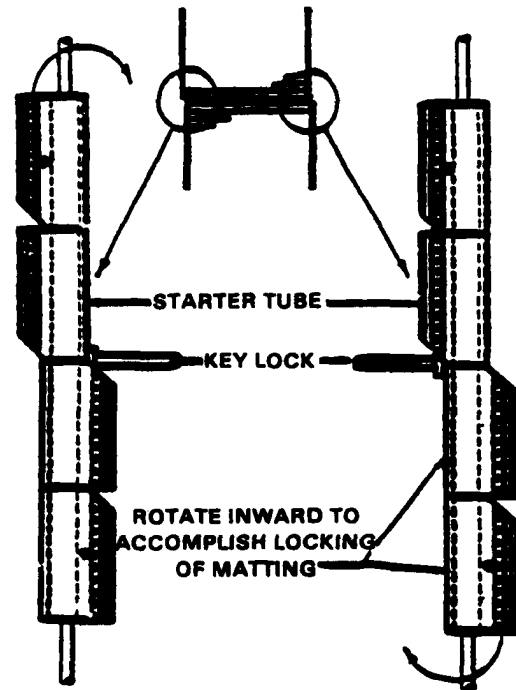

FIGURE D-6. TOWING TUBE AND KEYLOCK



Place sufficient towing tubes (15 on one side and 20 on the other) and mandrels with connector fittings to accommodate total patch. If there are fewer than five mats remaining at the end of the patch, use a short mandrel for each one. Towing tubes should be placed with prongs located identical to the starter tubes.

- After all tubes are placed on the mandrels (total of 2 starter tubes and 33 towing tubes on each side), place the stop and end cap on each end of the mandrel. (Do not tighten end caps until total matting patch has been assembled.)

Method B. As the first mat is placed starting a new row, connect the towing tubes to the left (looking toward the keylock) side of the matting. After each row of mats has been completed, connect the towing tube to the right side of the matting. Insert the locking bar between the mats and the tube as each connection is made. Place a starter tube on each side of the keylock, on each side of the patch (four starter tubes required). After all tubes are placed (15 on one side and 20 on the other), insert a long mandrel with tapered bullet nose attached in the tube, from the end of the patch (Figure E-7).

- Using the connector fitting, connect another long mandrel to the first mandrel. Be sure that the connector is threaded all the way into the mandrel and no threads are showing. Push this assembly into the towing tube and connect another long mandrel. Repeat this procedure until the bullet nose emerges at the opposite end of the towing tube. It will be necessary to install one extra mandrel so as to provide adequate spacing to remove the bullet nose and install towing bar stop and cap.
- After the towing bar stop and cap have been installed on one end, pull the mandrel so that the stop is flush against towing tube. Then remove the additional mandrel from opposite end and insert a towing bar stop and cap at that end. Make sure that the long end of these stops is facing in toward the patch and they clear the mat ends.
- Tighten the end caps equally, using the crescent wrench provided in the tool chest. If the panels expand so that the patch is longer than the assembled towing tube, add more stops (as a shim) from the spare stops provided in the kit. Tighten the caps at each end of the tube as tight as possible. Make sure that tubes are seated correctly.

Method C. Attaching Towing Tubes (Preferred Method). This is a build-as-you-go method that is done concurrently with the mat assembly.

- Use one long connector to connect two long mandrels on each side of the end of the keylock.
- After mandrels are connected and laid out, slide two starter tubes, centering them on each mandrel at the center connector fitting. Remember, starter tubes are 1 inch longer than the towing tube and do not have holes drilled for the towing harness.
- Since the matting is always laid from left to right, the starter tube that receives the first piece of matting placed on the keylock must be placed on the mandrel with the prongs facing up. The starter tube that receives the last piece of matting from the

first row must be placed on the mandrel with the prongs up and (when connected to the end of the matting) must be rotated 180 degrees on the mandrel to the prongs down position.

- Initial and final attachment of each tube on every row will be locked in with a locking bar. Additional towing tubes should be placed on each mandrel as they are needed, staying ahead of the mat-laying crew at least one mandrel length until the job is done.
- When all towing tubes have been installed on mandrels, place stop and end cap into the ends of each mandrel. Make sure that the long end of the stops are loose and are facing toward the patch.

FIGURE D-7. TOWING MANDREL AND MANDREL FITTINGS

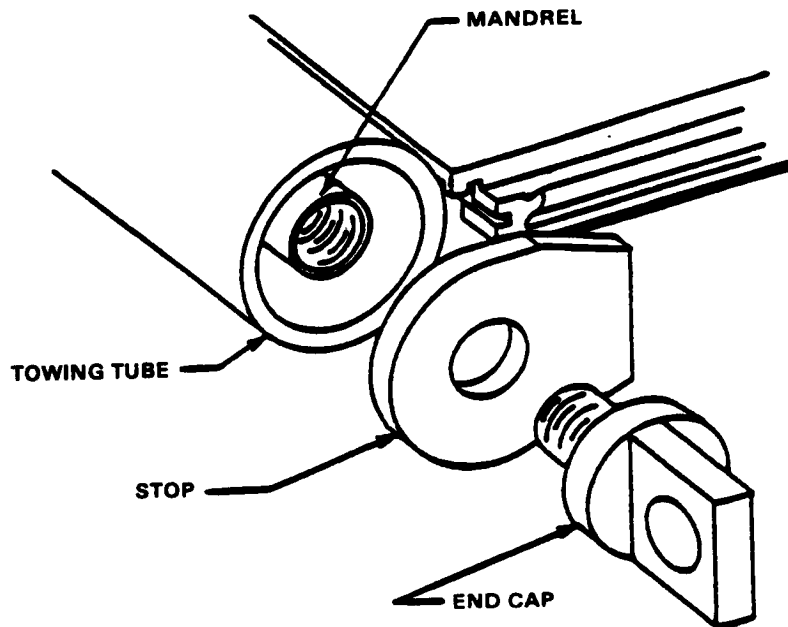

Assemble the Towing Tubes (Reverse Tubes)

Inventories of select RRR kits indicate that some of the towing tubes supplies are reverse of the standard and cannot be assembled as recommended by Method A or Method B. These tubes are readily identifiable when compared to the standard towing tube (Figure D-8). Following is the recommended procedure for assembling the reverse towing tubes:

- Select sufficient reverse towing tubes, usually 35, to complete a towing tube assembly. (Note: Reverse and standard towing tubes cannot be intermingled in a towing tube assembly.) The reverse started towing tubes cannot be used in the assembly. (Starter tubes are 2 inches longer and do not have a hole in the tube to attach the towing clamp.)

FIGURE D-8. COMPARISON OF STANDARD AND REVERSE TOWING TUBES

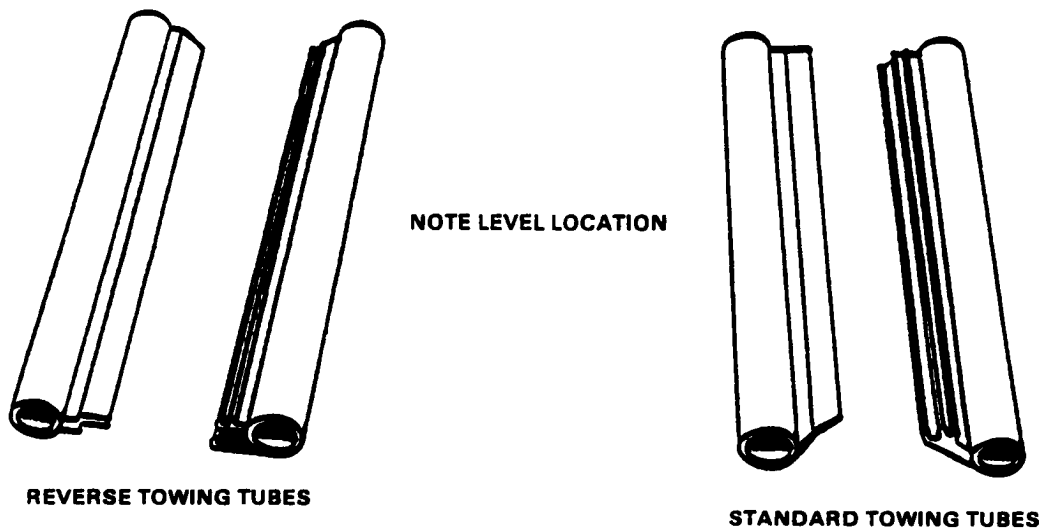

- The standard towing tube and keylock assembly prior placing AM-2 matting will resemble the diagram as shown in Figure D-9.
- To assemble the reverse towing tubes, place a piece of 1 1/4-inch pipe, 1 3/4 inches long (threaded or unthreaded) on a 20-foot piece of assembled mandrel, centered on the connector fitting. Place the reverse towing tubes with flat end toward center (Figure D-10).
- Proceed with assembly as detailed in Method A, except reverse the tube.
- Assembly can also be completed by Method B, except tubes are reversed and when mandrel is installed, pipe spacer must be used.

FIGURE D-9. STANDARD TOWING TUBE AND KEYLOCK ASSEMBLY

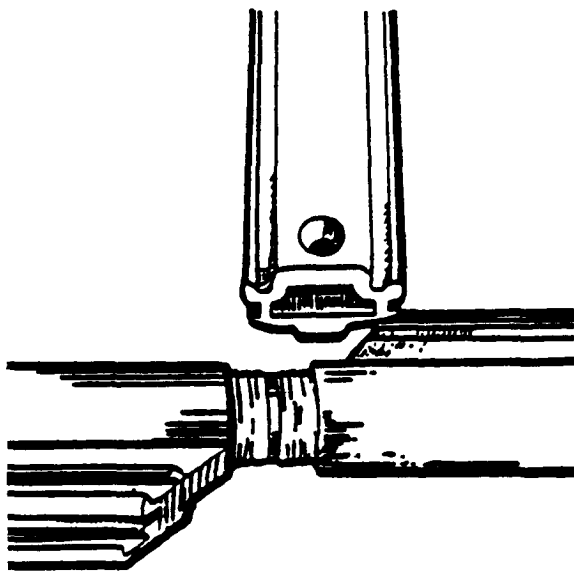
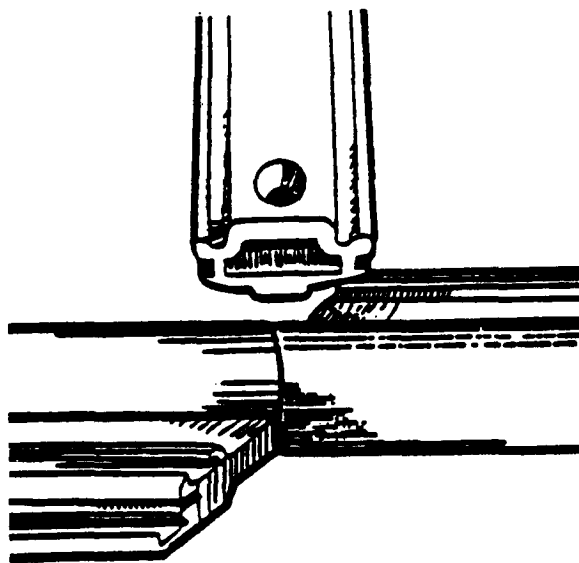
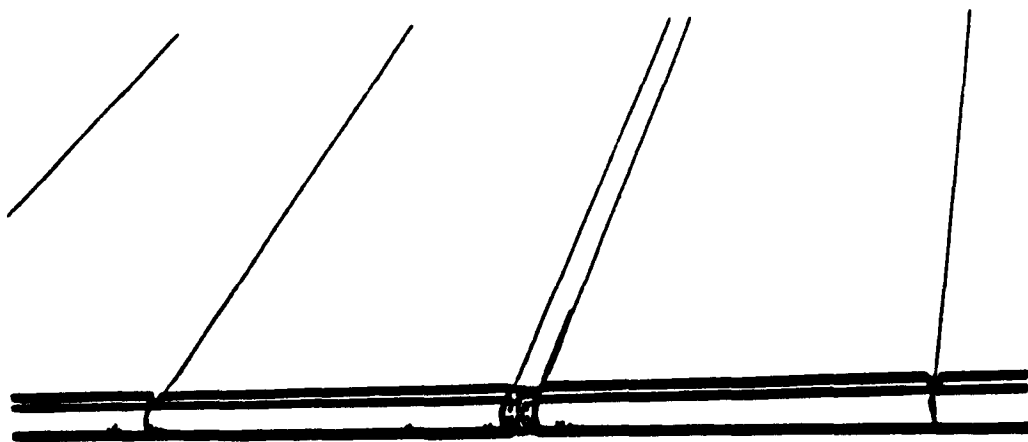

FIGURE D-10. REVERSE TOWING TUBE AND KEYLOCK ASSEMBLY



- Assembled patch will resemble diagram as shown in Figure D-11.
- Tighten towing tube assembly as previously described in standard towing tube assembly.

FIGURE D-11. ASSEMBLED PATCH TOWING TUBE



Assemble the Patch

Each patch assembly should be stored incrementally. This procedure will identify and load the patch assembly. To keep confusion to a minimum, each patch assembly should be delivered in total to the selected assembly area. (Note: If a fourth trailer is available or one of the three authorized RRR lowboy trailers is not required for moving the dozers, considerable time of the repair cycle may be gained by preloading the tool chests and compartment chests. However, movement of the dozers has priority. The chest delivery may occur just after the repair areas have been selected. Assembly of the keylock and towing tubes can proceed while waiting for remaining AM-2 matting.)

- Matting should be loaded on the lowboy in reverse order of use to allow efficient assembly.
- Truck the matting and tools to the selected assembly area. Be careful in unpacking the materials and tools not to damage the pallets and crates, for they must be reused to store the matting patch when it is disassembled later.
- Proper off-loading and positioning the bundles of AM-2 matting enhance the assembly effort. Bundles of matting are off-loaded with the forklift attachment. Bundles should be positioned on wooden dunnage to ease the removal of metal and plates. Positioning bundles on dunnage should be accomplished so matting can be placed by matting teams with shortest walking distance. If properly positioned, mats can be placed directly from bundles without rotating.
- Starting with the full size mats, connect a row of four 12-foot mats and one 6-foot mat to the keylock. Insert the locking bar at each end joint, as well as a locking bar at both of the towing tube connections. Now lay a second row using the same procedures. The minimum required length of the patch is 77 feet 6 inches (including ramps), but may be longer, depending on the size of the crater. The 54-foot width is constant. For a longer patch, get materials from another repair kit. Attach the towing tube as previously described.
- Double check to make sure that the first two rows of mats and keylock are straight. Then, starting with a full size mat, lay one row of mats on the other side of the keylock to keep the keylock shifting. After the matting has been placed on each side of the keylock, begin laying matting on both sides at the same time.
- Use a 3/16-inch locking bar as a spacer between mats in assembling the patch. (See Figure D-12 for a graphic illustration of how these bars are placed on edge.) This locking bar ("T" spacer) is left in place for at least three rows back from the row presently being installed.
- After the patch has been completely assembled, the towing tube will have been assembled. Tighten the end caps as previously indicated.

FIGURE D-12. USE OF LOCKING BAR IN ASSEMBLY PATCH AND CORRECTION OF MISALIGNMENT

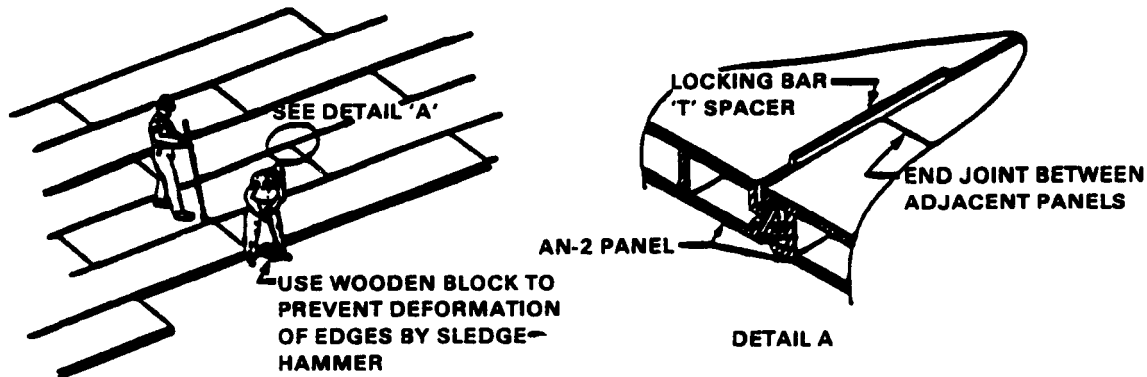

PERTINENT SAFETY PUBLICATIONS

AFOSH STD 127-31, "Personal Protective Clothing and Equipment"

AFOSH STD 127-43, "Flammable and Combustible Liquids"

AFOSH STD 161-1, "Respiratory Protection Program"

NIOSH 75-119, "NIOSH Certified Personal Protective Equipment"

NIOSH 77-139, "Working with Solvents"

NIOSH 78-185, "Safety in Manual Materials Handling"

NIOSH 78-206, "Working Safely with Flammable and Combustible Liquids"

NIOSH 78-215, "Criteria for a Recommended Standard Occupational Exposure to Diisocyanates"

Clayton and Clayton, ed., "Patty's Industrial Hygiene and Toxicology," Third Edition

International Isocyanate Institute, Inc., "Recommendations for Waste Disposal from Polyurethane Foam Manufacture," May 1979

Upjohn Chemical Division, CD-5, rev. 7/83, "Workers Guide to Using Isocyanates and Polyurethane Safely"

Upjohn Chemical Division, CD-1, rev. 8/82, Technical Bulletin 107, "Precautions for the Proper Usage of Polyurethane, Polyisocyanurates, and Related Materials"

MATERIAL SAFETY DATA SHEETS

Material safety data sheets must be obtained from the manufacturers of the two approved polyurethane resins and the suggested solvent. Persons handling these materials should familiarize themselves with the listed precautions and handling recommendations.

APPENDIX E

UNEXPLODED ORDNANCE AND EXPLOSIVE ORDNANCE DISPOSAL

As discussed in Chapter 2, the Army engineer unit may be tasked to assist in the removal and/or disposal of UXO when this mission exceeds the personnel and/or equipment capabilities of the air base personnel. This decision will be made jointly by the Army commander and the air base commander or designated representative in the DCC or SRC, Two conditions which may exist are disposal of defuzed UXOs and disposal of UXOs which have not been defuzed.

DISPOSAL OF DEFUZED UXOS

A mission that is likely to be tasked to the Army engineers is to carry defuzed bombs which have been flagged safe by EOD personnel to a disposal site. This mission is well-suited for the battalion's dump truck and bucket loader assets. Before loading the bomb, the bed of the dump truck should be partially filled with debris or sand approximately two-thirds full. A low spot in the middle of the bed should be made with the bucket of the loader and/or hand shovels. The idea is to have at least 2 to 3 feet of soil on each side of the bomb once it is put in the bed with special consideration given to the headache board side of the truck. The bomb should be lifted using ropes, nylon straps, and chains tied around the bomb and then tied to the bucket of the loader. Loaders should not try to pick up the bomb in their buckets! The bomb should be lifted in a manner that will keep it angled in the same manner as when on the ground. Keep the ropes around the bomb after the bomb has been set in the dump truck. They will be needed to lift the bomb out of the truck at the disposal site.

DISPOSAL OF UXOS WHICH HAVE NOT BEEN DEFUZED

If EOD personnel are unable to defuze UXOs in the Army engineer unit's area of operations because they are overcommitted, and if the DCC determines that the mission cannot be delayed any longer, the DCC may direct the engineer unit to dispose of the UXOs in order to continue with the mission. Note that Army engineer personnel will not attempt to defuze any UXGs. Army engineers can dispose of UXOs which have not been defuzed by blowing the ordnance in place. Selecting this course of action depends on the availability of explosives, size and type (high explosive, chemical, or incendiary) of UXO, how close the UXO is to personnel and property, and willingness to accept the effects of the explosion.

- **High Order vs Low Order Detonations.** A low order detonation is when a bomb detonates with less than its designed explosive force. An example would be if a 200-pound bomb exploded with a force of only 40 pounds. The remaining 160 pounds may have either burned after the explosion or remained in its solid state. A high order detonation is when a bomb detonates with its designed force. An advantage to blowing a UXO in place is that it is possible for a low order detonation to be accomplished under controlled circumstances. If blown in place the bomb should be surrounded with berms first so that the force of the blast will be directed upwards.

- **Placement of the Explosive Charge.** A 1 1/4-pound block of C4 or TNT is enough to set off a UXO. The best spot on the UXO to place the explosive is to the rear of the bomb, 6 inches forward of the fin assembly seam (Figure E-1). This is where the skin of the bomb is usually thinnest and the likelihood of a lower order detonation is the best. The C4 could be primed electrically or nonelectrically. A time fuze would normally be the most practical method. The minimum standoff distance when detonating any UXO for personnel under cover is 300 feet in a wartime situation. Protective distances greater than 300 feet may be advisable when detonating UXOs greater than 500 pounds. However, the need for such a large danger fan must be weighed against the priority of other missions in the enlarged area which would have to be halted during the demolition.

FIGURE E-1. UXO EXPLOSIVE PLACEMENT

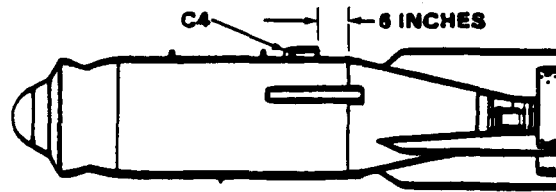

- **Advantages and Disadvantages.** There are several advantages to this method. First, it is a fast and easy method that exposes a minimum number of personnel to the UXO hazard. Second, the effects of the explosion can be minimized using protective measures such as berms. Finally, the time of the explosion can be controlled, thus saving time for personnel who have to be evacuated from nearby buildings. There are several disadvantages to detonating a UXO in place. One disadvantage is that the UXO is likely to leave a crater on the runway. Another problem is that the method is ineffective against chemical and incendiary bombs. Also, if the UXO is near utility lines or a building, the consequences of its detonation must be carefully considered. The detonating in place method is best used on high explosive (HE) bombs off the runway and at least 300 feet from any structures.

APPENDIX F

ARMY FACILITIES COMPONENTS SYSTEM

The Army Facilities Components System (AFCS) is a military engineering construction support system for planners and commanders to use in selecting, planning, and constructing facilities and installations needed in the theater of operations. It has worldwide application and can be used for developed and undeveloped theaters in any geographic area. The system provides standards of construction, construction phasing, standard plans, bills of material, equipment and unit augmentation, and general guidelines for the construction effort required for given facilities. It also provides data on construction materials and techniques used in a theater of operations.

The AFCS provides planning data in TM 5-301 and bills of material in TM 5-303 supporting the pavement repair concepts and materials described in this manual. Concept drawings are shown in TM 5-302. These drawings are intended to illustrate the concept planning data in TM 5-301. The AFCS facility numbers 11100AA through 11100EF identify "emergency repairs" and "repairs beyond emergency" for crater diameters of 15, 20, and 30 feet and span diameters of 3 and 6 feet. The planning data are organized in the following five general AFCS facility groupings:

Numbers 11100AA-AV cover emergency repair crater fills for the three sizes with and without water in the hole.

Numbers 11100BA-BJ cover emergency repair FOD covers.

Numbers 11100CA-CM cover beyond emergency repair crater fills for the three crater sizes.

Numbers 11100DA-DF cover beyond emergency repair concrete caps.

Numbers 11100EA-EF cover repairs for spans.

Background

The AFCS was designed in response to the need for an improved construction planning and supply system. Since its inception in 1951, AFCS has grown to a mature military engineering construction support system. This includes planning guidance, detailed construction drawings, and computer updated bills of material for over 4,000 facility designs. The AFCS is used by major commands and agencies for their planning, estimating, training, and actual construction activities.

References

TM 5-301, Army Facilities Components System - Planning:

This manual explains the concept and use of the system and contains tables of installations and facilities in the system. It is published in four volumes, each of which addresses a separate climate zone.

- TM 5-301-1 Temperate
- TM 5-301-2 Tropical
- TM 5-301-3 Frigid
- TM 5-301-4 Desert

The purpose of TM 5-301 is to provide material costs, logistical data, and engineering data for planning construction support. Its planning tables show requirements for real estate (acres), water supply and sewerage (gallons/day), electrical connected loads (kilowatts), aggregates (cubic yards), and construction effort (vertical, horizontal, and general construction man-hours).

TM 5-302, AFCS - Design:

This multi-volume manual contains detailed design drawings for installations and facilities. The TM 5-302 also includes:

- Critical Path Method (CPM) diagrams for construction management
- Material procurement process diagrams

TM 5-303, AFCS - Logistic Data and Bills of Material:

This manual is used by planners, builders, and suppliers to identify materials used to construct the desired facilities. It contains material descriptions, units of issue, quantities required, and National Stock Numbers.

TM 5-304, AFCS - User Guide:

This manual explains how to use the AFCS. It contains terminologies, definitions, requisition and supply procedures, unit productivity data, and example problems. It also provides general guidance and information on theater of operations construction.

Foreign Equivalent Construction Stock Items and Local Building Components:

These are unnumbered publications which provide a country-by-country construction material availability and compatibility and local construction practice listing for the following geographic areas:

- Europe
- The Middle East
- Asia and Africa
- Central and South America

Construction Standards

Joint Chiefs of Staff (JCS) Publication 3 defines only two construction standards for planning, designing, and constructing facilities in support of military contingency operations. Selection of which standard to use is based primarily on the expected duration of the contingency operation and is set by the theater commander. Because of the short design life of AFCS facilities, safety factors are the minimum necessary to ensure personnel and equipment safety in the accomplishment of the mission. The AFCS facility designs are based on the following two JCS standards:

- INITIAL --- design life of up to 6 months
- TEMPORARY --- design life of up to 24 months

The choice of which standard to use depends on the availability of resources and the anticipated duration of use.

Automated AFCS Planning

The Theater Army Construction Automated Planning System (TACAPS) is a series of computer programs and data collection procedures. The system is designed to provide military planners and commanders with the means to quickly access the AFCS data files and develop plans and requirements for theater or contingency construction projects. The user accesses information from the TACAPS system via a terminal/modem and telephone communications link. The TACAPS provides immediate, accurate AFCS data since the system is continually updated with AFCS changes. The long term application of TACAPS will be to make TACAPS compatible with unit personal computers (that is, TACAPS floppy disks).

Theater Oriented Guide Specifications

Theater oriented guide specifications (TOGS) are a set of specifications designed to be incorporated with the AFCS drawings to make AFCS contract executable. Each of the TOGS sections covers an item of construction. The TACAPS data base references the appropriate TOGS sections for each AFCS facility design. The TOGS are unique in that they are self-contained without reference to commercial specifications and Federal standards. The language is unambiguous and assumes the contractor is operating in good faith, and the Army assumes the risk for existing site conditions.

Procurement of Construction Material from Foreign Sources

The supply procedures and construction materials identified in TM 5-303 are applicable when requisitioning AFCS construction material from CONUS; however, the supply procedures are not applicable for foreign source procurement. Prior to procuring materials, the user should perform engineering design checks to determine whether foreign construction material is compatible with US components. For example, materials and equipment based on the metric dimensioning system should be checked for comparability.

AFCS Flexibility

The AFCS, uses a building block concept to permit maximum flexibility. The building blocks are items, facilities, and installations.

- **Item.** An item is any construction material or equipment that makes up a larger product. Each item has an associated National Stock Number, description, unit of issue, and quantity.
- **Facility and Subfacility.** A facility is a group of items designed to provide a service. It can also be an item of equipment that, as an operating entity, contributes to the performance of a function by providing some type of physical assistance. Each facility has an associated facility number, description, unit of issue, shipping weight, shipping volume, and cost.
- **Installation.** An installation is a group of facilities designed to provide some specific service or support to some military function in a theater of operations. Each installation has an associated installation number, shipping weight, shipping volume, and cost.

The AFCS is an excellent tool for detailed construction planning. Using the building block concept, standard AFCS facilities and installations can be modified to accommodate user needs. While the AFCS designs are constructible and functional, modifications may be necessary to accommodate unique user requirements, site conditions, or material availability.

The AFCS remains the principal source of data for planners and builders regarding construction requirements for the theater of operations. It is used as the Army facilities components file for the Civil Engineering Support Plans (CESPs) for all major OPLANs.

AFCS Limitations

Users must recognize the following limitations when using AFCS:

- The AFCS is continually under revision; therefore, AFCS publications can quickly become out of date.
- The AFCS is not an authorization document for the prestockage or ordering of construction material.
- The AFCS facilities and installations are not stored in CONUS warehouses awaiting shipment.
- When materials are ordered from CONUS, they are not packaged as one complete facility.

Special Note

The AFCS is managed by the Office of the Assistant Chief of Engineers (HQDA (DAEN-ZCM)), with technical (engineering and logistics) support provided by the Huntsville Engineer Division. Either of these offices may be contacted for assistance on the use of AFCS.

APPENDIX G

AIR FORCE ENGINEERING ORGANIZATIONS

There are two Air Force engineering units that will be involved with ADR, RED HORSE and Prime BEEF. This appendix discusses in detail the mission and capabilities of the RED HORSE and Prime BEEF units.

RED HORSE Mission

The RED HORSE mission is to provide a highly mobile, self-sufficient, rapidly deployable, civil engineering capability from active and mobilized ARF, RED HORSE squadrons, as required to--

- Perform heavy damage repair for recovery of critical Air Force controlled facilities.
- Perform required engineering support for beddown of weapon systems, particularly in bare base environments, during initial and sustained phases of contingency operations.

Each complete squadron has the following capabilities:

- To deploy as a squadron, or as unit echelons, depending upon mission requirements.
- To function independently, to a limited degree, for a limited time, from host base operating support when deployed as a whole unit.
- To deploy to remote areas within a theater, augmented by security forces when required.

Deployment Concepts

RED HORSE squadrons are organized into three deployment echelons, RH-1, RH-2, and RH-3.

- RH-1. An air-transportable RED HORSE squadron echelon (16 persons) which is prepared for deployment 12 hours after notification. It is capable of performing advanced air base surveys, site layout, and preparation for the orderly establishment and future development of a base of operations during contingencies.

- RH-2. An air-transportable RED HORSE squadron echelon (93 persons) which is prepared for deployment 48 hours after notification. It is capable of performing heavy bomb damage repair, erecting basic shelters, and performing limited earthwork. It is capable of light base development (such as installing aircraft arresting systems, expedient air base matting, and essential utility systems) during the initial phase of contingencies.
- RH-3. A surface movement RED HORSE squadron echelon (295 persons) which is prepared for deployment 6 days after notification. It is capable of performing heavy repair, base hardening (vertical and horizontal), and air base expansion, including the erection of relocatable facilities to support contingency operations.

Each echelon has its own separate personnel and equipment. They provide support to Air Force component commanders or unified commands and specified commands, as outlined in unified command operation plans (OPLANS), Air Force support plans, and concept plans (CONPLANS). Deployment concepts for RED HORSE squadrons in these plans include--

- Deployment to a bare base where RH-1 and RH-2, augmented by fire fighting or crash rescue teams (Prime BEEF fire fighting teams as required), would constitute the initial civil engineering force.
- Deployment when the Time-Phase Force and Development List (TPFDL) calls for civil engineering augmentation. In this case, mobile engineer emergency force (Prime BEEF) teams provide the initial response, and RED HORSE squadrons provide the follow-on capability of heavy repair and construction.

When three or more squadrons are assigned to the same theater of operations, the major command (MACOM) may establish Civil Engineering Groups (CEG) to centrally direct the RED HORSE efforts. Prior approval must be obtained from HQ USAF before a CEG is established. Contingency operations may be accomplished in two phases, initial and sustained.

Response Time

The three echelons must be capable of deploying (ready to load) within the following specified times:

Echelon	Deployment Capability
RH-1	notification + 12 hours
RH-2	notification + 48 hours
RH-3	notification + 6 days

In peacetime, squadrons can be based either in CONUS or overseas. They have a permanent Unit Home Station (UHS), and may send personnel in support of individual or several projects on a Temporary Duty (TDY) basis, or they may have Permanently Detached Units (PDU).

PRIME BEEF

Purpose

The Prime BEEF program is an Air Force MACOM and base-level program that organizes civil engineering forces for worldwide direct and indirect combat support roles. It assigns civilian and military personnel to both peacetime real property maintenance and wartime engineering functions. Along with RED HORSE, Prime BEEF teams are the civil engineering forces that prepare bases for and recover them from war damage. Prime BEEF teams also provide base operations and maintenance support, and accomplish crash rescue and fire suppression. They support natural disaster recovery operations, and assist in peacetime, engineering projects and training exercises.

Concept and Policy

- Manpower and Personnel.

Military. The number and location of Prime BEEF teams are determined by the MACOMs, and the teams are manned by the bases according to guidance provided by HQ Air Force Engineering and Services Center/Directorate of Readiness (AFESC/DEO). The numbers, skills, and grades of military civil engineers needed for mobility are determined by potential combat requirements. All military civil engineers are included in the Prime BEEF program. Although Prime BEEF teams are postured in the manner that best meets wartime needs, base civil engineering manpower, mission, and workload are based on peacetime standards that will vary from location to location. The expedient engineering and war damage repair techniques are taught to all base-level Prime BEEF team members. Civil engineering military and civilian craftsman routinely work side by side in peacetime, and this provides Prime BEEF teams the capability to perform anticipated wartime tasks. Prime BEEF team members are postured to meet essential wartime requirements within engineering functional areas for rapid, short-notice, wartime deployments. Therefore, they are not tasked to augment other wartime functions on a preplanned basis. In contingency or exercise operations, Prime BEEF duties take precedence over peacetime nonemergency duties and any additional or augmentation duties. At certain CONUS bases, military personnel may be required to provide direct combat support. These individuals make up the strategic withhold force. The strategic withhold force provides direct combat support for strategic offensive and defensive operations in the CONUS, and must be kept to the minimum essential number so as not to significantly reduce the number of military personnel available for deployment.

- **Civilian.** Civilians are vitally essential in base civil engineering to provide a minimum CONUS indirect combat support sustaining capability, to maintain continuity of operations, and to provide training for our military members. The CONUS sustaining program relies on the civilian workforce to meet the vast

majority of essential wartime tasks to sustain base operations during contingencies and mobilization. This workforce is augmented by relocated civilians, civilian overhires, and contingency contracts, as soon as possible after military personnel deploy. Pre-identified Individual Mobilization Augmenters (IMA) may be used temporarily, in positions that should be or are usually filled by civilians, when no civilian manpower authorization or skill is available.

- **Team Capability.** Prime BEEF teams have a variety of capabilities to meet combat demands. Teams may be deployed individually or in groups to support peculiar operational needs. These deployments may augment existing civil engineering forces or provide civil engineering capability where none exists. Prime BEEF teams are postured to provide an immediate mobile response to assure aircraft launch and recovery and high sortie generation rates. These teams receive an equivalent priority in manning, equipping, and training. There are currently six different Prime BEEF contingency forces listed in AFR 93-3. It is sometimes necessary to tailor special Prime BEEF teams, called variable teams, for a particular task for a limited duration. Team composition and equipment vary as the situation dictates.
- **Response Time.** Prime BEEF teams are deployable worldwide on a 28-hour notice for Air National Guard, and a 22-hour notice for active duty. This time period includes a 4-hour period for deployment after the deployment order is received.

APPENDIX H

TYPICAL CREW AND EQUIPMENT CONFIGURATIONS

As previously discussed, there are several methods available for accomplishing emergency and beyond emergency repair. The selection of a specific method will depend upon equipment and personnel availability, materials on hand, and soldier expertise. This appendix provides the Army commander a guide as to what equipment and personnel assets are required for each repair method.

RECOMMENDED ARMY ORGANIZATION

PAVEMENT REPAIR

SAND GRID

Equipment:

- Air compressor
- Dump trucks
- Bucket loaders
- Portable compactors/hand tampers
- Shovels
- 25-foot sand screed beams
- Vibratory roller
- Surface roughness checking devices:
 - Two upheaval strings (locally manufactured)
 - One string line (70 feet long)
 - Five percent slope measuring straightedge (locally manufactured)

Personnel:

- Approximately one platoon per large crater

CONCRETE CAP

Equipment:

- Concrete-mobile mixers
or host nation concrete trucks
- Bucket loaders
- 10-ton vibratory rollers
- Portable compactors/hand tampers
- Bulldozers

TC 5-340

- Road graders
- Dump trucks
- Water truck
- Screed beam
- Concrete pedestal
- Air compressor
- Concrete finishing equipment:
 - Push brooms
 - Hand trowels
 - Bull floats

Personnel:

- Approximately one platoon per large crater
- Approximately one platoon per two small craters

STONE AND GROUT

Equipment:

- Grout-mixing equipment
- Bucket loaders
- 10-ton vibratory rollers
- Portable compactors/hand tampers
- Bulldozers
- Road graders
- Dump trucks
- Water truck
- Screed beam
- Air compressor
- Concrete finishing equipment:
 - Push brooms
 - Hand trowels
 - Bull floats

Personnel:

- Approximately one platoon per large crater
- Approximately one platoon per two small craters

SPALL REPAIR

Equipment:

- Silikal/Concrete/Bituminous Mix/Stone and Grout
- Screed beam

Air compressor
Pioneer tool kit
Finishing equipment

Personnel:

Approximately one squad per 100 spalls

STRUCTURE AND UTILITY REPAIR

EXTERIOR UTILITY REPAIR TEAM

Equipment:

Air compressor (250 cfm) w/pneumatic tool kit
Crane
Dump truck
Bucket loader
Portable compactors
Portable pump
Pioneer tool kit
Plumber's tool kit
Carpenter's tool kit
Electrical tool kit

Personnel:

Approximately one squad per utility reconnection
Approximately one platoon per utility bypass
Approximately one company per major utility reconstruction

INTERIOR UTILITY REPAIR TEAM

Equipment:

Electrical tool kit
Plumber's tool kit
Pioneer tool kit
Carpenter's tool kit

Personnel:

Approximately one squad per facility requiring minor restoration
Approximately one platoon per facility requiring major restoration

STRUCTURE REPAIR TEAM

Equipment:

- Carpenter's tool kit
- Pioneer tool kit
- Concrete tool kit
- M919 Concrete Mobile
- Air compressor (250 cfm) w/pneumatic tool kit, especially jackhammer and compactors

Personnel:

- Approximately one squad per structure requiring minor restoration
- Approximately one platoon per structure requiring major restoration

The exact number required for each type of equipment listed will vary for the repair depending on several factors. For this reason no quantities have been offered. A requirement to haul aggregate from a remote site rather than using a prestocked pile adjacent to the runway will necessitate a change in the number of dump trucks and bucket loaders used. Commanders may have to make key allocation decisions when elements of the unit are engaged in simultaneous repair efforts. Certain tasks can be accomplished in less time if equipment assets are increased at the jobsite. However, a saturation point is quickly reached where additional assets do not decrease repair time. This is particularly true for small crater repair efforts. The use of an FM radio net within a crater repair team (controlled by the repair officer in charge (OIC) or noncommissioned officer in charge (NCOIC)) will greatly increase efficiency, operability, and safety. In conducting ADR training, units must carefully monitor equipment use in order to be best able to allocate that equipment in the most productive manner during a conflict.

The Air Force has spent considerable money, time, and effort in developing recommended team sizes for various locations on the air base. Given their criteria for 4 hours for emergency repair, this early organizational planning is critical. Army engineers can use the Air Force repair team planning sizes when practicing Air Force methods. Of course, some equipment is unique to the Air Force and can be closely substituted with Army equipment.

Fortunately, beyond emergency repairs do not have to be taken care of immediately, thus leaving the Army engineer with more time to plan team organization.

AIR FORCE ORGANIZATION

COMMAND POST

(Same for either crushed stone or precast concrete)

Personnel:

- OIC
- Radio operator
- Two map plotters

CRUSHED STONE METHOD

LARGE CRATER REPAIR TEAM

Personnel:

NCOIC

Four equipment operators

Three laborers (to do surface roughness checks, hand leveling of fill or stone, dump truck "spotting", second crater commander)

Equipment:

Two 4-cubic yard, front-end loaders

One dozer

One 10-ton, self-propelled, vibrating roller

Three shovels

One radio

Surface roughness checking devices:

Two upheaval strings (locally manufactured)

One string line (70 feet long)

Five percent slope measuring straightedge (locally manufactured)

SMALL CRATER REPAIR TEAM

Personnel:

NCOIC

Three equipment operators

Two laborers (to do surface roughness checks, hand leveling of fill or stone, dump truck "spotting", second crater commander)

Equipment:

One 2 1/2-cubic yard, front-end loader with "4-in-1" bucket

One multifunctional excavator with bucket and jackhammer attachments. Compactor plate would only be used if vibrating roller were deployed to another crater and compaction became critical.

One 10-ton, self-propelled, vibrating roller

Two shovels

Two rakes

One radio

TC 5-340

Surface roughness checking devices:

Two upheaval strings (locally manufactured)

One string line (70 feet long)

Five percent slope measuring straightedge (locally manufactured)

STONE STOCKPILE TEAM 1

Personnel:

NCOIC

Twelve truck drivers

One equipment operator

Equipment:

Twelve 5-ton dump trucks

One 2 1/2-cubic yard, front-end loader with bucket. The number of loaders depends on the haul distance from the stockpile to the crater. The shorter the haul distance, the more loaders are needed to avoid delays at the stockpile.

One radio

STONE STOCKPILE TEAM 2

Personnel:

NCOIC

Seven truck drivers

One equipment operator

Equipment:

Seven 8-cubic yard dump trucks

One 2 1/2-cubic yard, front-end loader with bucket

One radio

DELIVERY TEAM

(This team delivers dozers, AM-2, fiberglass mats, and span repair materials to the MOS.)

Personnel:

NCOIC

Three truck drivers

Six equipment operators

One laborer (to hook up FOD covers)

Equipment:

- Three 10-ton tractors towing 22-ton trailers
- Two 2 1/2-cubic yard, front-end loaders with forks (one loading AM-2 and spall repair material, the other unloading AM-2 on the runway)
- Three 5-ton dump trucks (to carry span repair material)
- One 4-cubic yard, front-end loader (towing fiberglass mats)
- Six sets of towing chains and towing brackets for fiberglass mats
- One radio

FIBERGLASS MAT-BOLTING TEAM

Personnel:

- NCOIC
- Four laborers
- One driver/radio operator

Equipment:

- One 1/2-ton pickup
- Drilling equipment, including air compressor or electric generator
- Drill bits for bolts and countersinks (sized to be compatible with the rock bolts being used)
- 1 1/2-inch diameter drill bits (for polymer plug in asphalt pavements)
- Measuring cups (for mixing polymer material for asphalt pavement)
- Two handbrooms
- Two pairs of bolt cutters (capable of cutting 5/8-inch diameter rock bolts)
- Four hammers
- One radio

AM-2 MAT ASSEMBLY TEAM

Personnel:

- NCOIC
- Twelve laborers

Equipment:

- Drilling equipment, including air compressor or electric generator
- Drill bits
- Six handbrooms
- Two pairs of bolt cutters (capable of cutting 3/8-inch diameter bolts)
- Six ratchet spanners (for tightening holding down bolts)
- One radio

PRECAST CONCRETE METHOD

CRATER REPAIR TEAM

Personnel:

NCOIC Six equipment operators
Three laborers (to do surface roughness checks, hand leveling of fill or stone, dump truck "spotting", second crater commander)

Equipment:

Three front-end loaders (two 2 1/2-yard loaders and one 4-yard loader)
Multifunction excavator with pavement breaker
Concrete-cutting saw
1,500-gallon water truck
Screed beam
10-ton self-propelled roller
Surface roughness checking devices:
Two upheaval strings (locally manufactured)
One string line (70 feet long)
Five percent slope measuring straightedge
One radio

STONE STOCKPILE TEAM 1

Personnel:

Same as crushed stone stockpile team 1

Equipment:

Same as crushed stone stockpile team 1, except the loader should be upgraded from one 2 1/2-yard loader to one 4-yard loader

STONE STOCKPILE TEAM 2

Personnel:

Same as crushed stone stockpile team 2, except add one additional equipment operator

Equipment:

Same as crushed stone stockpile team 2, except replace the one 2 1/2-yard loader with two 4-yard loaders

DELIVERY TEAM

Personnel:

Same as crushed stone delivery team, except it is reduced by one equipment operator

Equipment:

Same as crushed stone delivery team, except that a loader is not needed to tow any matting

SPALL REPAIRS

Personnel:

NCOIC
Two laborers
One driver

Equipment:

One 1/2-ton pickup
Two shovels
Two handbrooms
One pickax
Two bricklayer's trowels
Two bricklayer's floats
One bucket (for solvent to clean tools)
One propane torch with gas bottle (to dry spalls)
Eight pairs of chemical-resistant gloves
Six pairs of safety goggles
Emergency eyewash or jerry can of water
Fire extinguisher
One radio

**EQUIPMENT CHECKLISTS FOR AN EMERGENCY REPAIR
CRUSHED STONE WITH FOD COVER AND SAND GRID METHODS**

1st SQUAD:

String Line	
Radios	As Required
Line Level	
CEOI	As Required
Tractor, Utility, JD 410 or SEE	1 ea
Bucket Loader, 2 1/2 CY	1 ea
Tamper, Gas Driven	1 ea
Engineer Toolbox	1 ea
Manila Rope	200 feet
Wheelbarrows	As Required
Pry Bars	As Required
Chain Saws	As Required
Shovels	As Required
Rakes	As Required

2d SQUAD:

Radios	As Required
CEOI	As Required
CUPV	1 ea
D7 Dozer	1 ea
Tamper, Gas Driven	1 ea
Shovels	As Required
Rakes	As Required

3d SQUAD:

Radios	1 ea
5/4T	1 ea
CEOI	1 ea
CUPV	1 ea
Electric Tool Trailer	1 ea
Light Set	As Required
Cable/Manila Rope	As Required
Ratchet Sets	As Required
Drills (FOD Cover)	As Required
916's w/Lowboys	As Required

EQUIPMENT CHECKLISTS FOR BEYOND EMERGENCY REPAIR CONCRETE CAP AND STONE AND GROUT METHODS

1st SQUAD:	
Screed Beam	As Required
Pedestal	As Required
Bull Floats	2 ea
2d SQUAD:	
Hoe	2 ea
Trowels	3 ea
Electric Tool Trailer	1 ea
Saws	2 ea
Carpenter's Box	2 ea
3d SQUAD:	
250 CFM Air Compressor	1 ea
Vibrator	2 ea
Trowels	3 ea
SWEEPING TEAM:	
Grader	2 ea
D7 Dozer	1 ea
5/41 w/sweeper	1 ea
STOCKPILE/DELIVERY TEAM:	
5T/20T	As Required
2 1/2 Cu Yd Loader	2 ea
5/4T	1 ea
QUALITY CONTROL:	
Soils Kit	1 ea
Wheelbarrow	1 ea
SPALL REPAIR TEAM (3d Squad):	
Truck, 2 1/2-ton	1 ea
250 CFM Air Compressor	1 ea
Trowels	As Required
Water Cans/Water Buffalo	As Required
NCOIC:	
Vibratory Roller	1 ea

TABLE H-1. ADR Training Materials

Material	Approximate Quantity Required Small Crater/Large Crater/Spall (Cubic Yards)	How Obtained
Well-graded, high-quality crushed stone Stone and grout Concrete cap	7/12/NA 9/16/NA	
3-inch uniformly-graded crushed stone (56-75 mm) Stone and grout	4/8 /NA	Local contractor
Portland cement (pounds) Stone and grout Concrete cap*	9694/16964/NA 4865/8826/99	
High/Early (Type III) Type I/Normal		Local contractor 5610-00-242-3792
Silikal	NA/NA/1	5610-01-151-1815
Sand grid (square yards)	39/70/NA	5680-01-198-7955 1 each section 8 ft x 20 ft x 8 in
Impervious membrane (square yards)	20/35/NA	Local contractor 6 mil polyethylene
Sand	9/16/NA	Local contractor
FRP Mat** (square yards)	20/35/NA	Local contractor
FRP Mat	20/35/NA	Mil P29242(YD) dtd 28 June 1985
AM-2 Mat (square yards)	20/35/NA	5680-00-089-7001

*This is for cement only. The amount of gravel, sand, and water required will be determined by the concrete mix design.

**Specific details for the materials and the fabrication procedures for the fiberglass reinforced with polyurethane mat are given on pages 98 and 99 of Rapid Runway Repair Interim Guidance, Air Force Engineering and Services Center, Tyndall Air Force Base, Florida, September 1984.

NOTE: This table is based on the following crater sizes:

- Small - 15 foot diameter, 4 foot average depth (26.2 cubic yards)
- Large - 20 foot diameter, 6 foot average depth (69.8 cubic yards)
- Spall - 3 foot diameter, 5 foot average depth (0.13 cubic yards)

GLOSSARY

Acronyms and Abbreviations

AC	asphalt cement
ACGIH	American Conference of Government Industrial Hygienists
ADA	air defense artillery
ADR	air base damage repair
AFCS	Army Facilities Components System
AFR	Air Force regulation
ALB	AirLand Battle
APOD	aerial ports of debarkation
AR	Army regulation
ARF	Air Reserve Force
BCE	base civil engineer
BRAAT	base recovery after attack
Bw	Bundeswehr
CBR	California Bearing Ratio
CE	compactive effort
CEG	Civil Engineering Groups
CESPS	Civil Engineering Support Plans
CL	low compressible clay
COB	collocated operating bases
CONPLANS	concept plans
CRAF	Civil Reserve Air Fleet
CSG	Combat Support Group
DAT	damage assessment team
DCC	damage control center
DIRS	damage information reporting system
DT&E	developmental test and evaluation
ENCOM	Engineer Command
EOD	explosive ordnance disposal
ESRC	Engineering and Service Readiness Center
FC	field circular
FOD	foreign object damage
FRP	fiberglass reinforced with polyurethane
ft	feet

GC	clayey gravel
GP	poorly graded gravel
GP-GW	poorly graded gravel with silty fines
GW	well graded gravel
GW-GM	well graded gravel with silty fines
HE	high explosive
HNS	host nation support
in	inch
ILS	instrument landing system
I MA	individual mobilization augmenters
JSCERDCG	Joint Services Civil Engineering Research and Development Coordinating Group
kg	kilogram
MAAS	Mobile Aircraft Arresting System
MACOM	major command
MAOS	minimum air base operating surface
MDAS	Manual Damage Assessment System
MDD	diphenyl-methane diisocyanate
MEK	methyl ethyl ketone
ML	low compressible silt
ML-CL	low compressible silt with some low compressible clay
ML-SC	low compressible silt with some clayey sand
mm	millimeter
MOB	main operating base
MOPP	military oriented protective posture
MOS	minimum operating strip
NA	not applicable
NBC	nuclear, biological, chemical
NCOIC	noncommissioned officer in charge
OIC	officer in charge
OPLANS	operation plans
OSHA	Occupational Safety and Health Administration
PCC	Portland cement concrete
PDU	permanently detached units
PFM	poly-impregnated fiberglass mats
ppm	parts per million
Prime BEEF	Base Engineer Emergency Forces
Psi	pounds per square inch
PSP	pierced steel planking
PVC	polyvinyl chloride
RAOC	Rear Area Operations Center
RED HORSE	Rapid Engineering Deployable Heavy Operational Repair Squadrons, Engineering

RRR	rapid runway repair
ROWPU	reverse osmosis water purification unit
SC	clayey sand
SM	silty sand
SM-ML	silty sand with low compressible silty fines
SM-SC	silty sand with some clayey sand
SM-SP	poorly graded silty sand
SOA	separate operation agency
SP	poorly graded sand
SRC	Survival Recovery Center
TACAN	tactical air navigation
TDY	temporary duty
TEO	training evaluation outlines
TLV	threshold limit values
TOE	Table of Organization and Equipment
UHS	Unit Home Station
USCS	Uniformed Soils Classification System
UXO	unexploded ordnance
WES	Waterways Experiment Station
WRM	War Reserve Materiel
WWI	World War I
WWII	World War II

Definitions

Air base damage repair (ADR).

The repair of an air base after it has sustained damage from hostile forces. This may include the emergency and beyond emergency repair of the runway surface and taxiways, the repair of utilities, buildings, hangars, control towers, and any other systems deemed by the Air Force base commander to be essential to the proper operation of that particular base.

Air Force Engineering and Services Center (AFESC).

A separate operating agency (SOA) located at Tyndall AFB, Florida. The Directorate of Readiness (HQ AFESC/D&EO) acts as the Air Force program manager for Base Civil Engineer (BCE) Contingency Response Planning.

AM-2 landing mat.

An extruded aluminum mat consisting of panels 12 feet long, 2 feet wide, and 1 1/2 inches thick. The surfaces are coated with an antiskid compound and each panel weighs approximately 114 pounds. The mat is assembled using various connectors to join the panels.

Apparent crater diameter.

The apparent crater diameter is the visible diameter of the crater, inside edge to edge at the original surface level, prior to debris being removed. In practice, this can be measured from pavement edge to pavement edge.

Bare base.

A base having a runway, taxiways, parking areas adequate for the deployed force, and possessing an adequate source of water that can be made potable.

Base Disaster Preparedness Office.

The office of primary responsibility for all activities and measures designed or taken to protect Air Force resources from the effects of attacks, natural disasters, and major accidents; to restore primary mission assets after disasters; and to fulfill the humanitarian disaster relief responsibilities of commanders.

Base recovery after attack (BRAAT).

A theater concept of recovering a base after conventional attack where resumption of flying operations is the first priority. Other recovery activities may be conducted concurrently; however, these activities must not impede the resumption of flying operations.

Beddown.

The provision of expedient facilities to meet the wartime needs of in- place and deploying forces.

Beyond emergency repair of surfaces.

Repair efforts designed to upgrade emergency repairs for increased aircraft traffic. This type of repair is expected to withstand unlimited sorties of fighter aircraft and 2,200 sorties of a C141B.

Collocated operating base (COB).

A base hosted by an ally that can be used to beddown Air Force augmented forces. The COBS require civil engineering support to accommodate reception, beddown, launch, and recovery of USAF aircraft. A COB may be a main, standby, or limited base of the allies.

Continental United States (CONUS).

United States territory, including the adjacent territorial waters, located within the North American Continent between Canada and Mexico, excluding Alaska and Hawaii.

Debris/Ejecta.

Material ejected from the crater including broken pavement and soil. Debris is sometimes usable as backfill material for crater repair (when the dimension of the debris does not exceed 12 inches).

Emergency repair of surfaces.

Rapid repair of runway damage which enables aircraft to be launched or recovered within four hours following an enemy attack of the air base. This type of repair effort is expected to withstand 1,000 sorties of an F4 (or 500 sorties of an F15) or 50 sorties of a C141B.

Explosive ordnance disposal (EOD).

The detection, identification, field evaluation, rendering safe, recovery, and final disposal of unexploded explosive ordnance. It may also include the rendering safe, and disposal of explosive ordnance which have become hazardous by damage or deterioration when the disposal of such explosive ordnance is beyond the capabilities of personnel normally assigned the responsibility for routine disposal.

Force beddown.

Providing minimum expedient facilities necessary for deployed units to become operationally ready (OR) and to survive enemy attack.

Foreign object damage (FOD).

Damage to aircraft caused by small, loose objects (usually debris on the runway) either hitting the aircraft (breaking lights or causing dents), being ingested in the engine and damaging the turbines, or damaging tires.

Fiberglass reinforced with polyurethane (FRP) and poly-impregnated fiberglass matting (PFM).

This term refers to a type of FOD prevention cover used by the Air Force in the performance of rapid runway repair. The cover consists of a layer of fiberglass (between 1 1/4- and 3/8-inch thick) which has been combined with a polyurethane resin. The resin gives the fiberglass a load-bearing capacity through stiffness caused by the physical properties of polyurethane. Older types of FRP mat have been reinforced with polyester, producing similar results. However, polyurethane reinforcement of fiberglass is the present reinforcement method recommended by the Air Force.

Harvest bare.

Nickname given to a bare base system. Harvest bare is a concept in mobility which offers

deployment of all supporting buildings to a bare base. These buildings are lightweight, have a modular design, and may serve as containers for items being used to set up the building. Hardest bare assets are designed to support 4,500 personnel in various Increments and are designated as war reserve materiel (WRM) and maintained in a ready -to-deploy status.

Large crater.

Pavement damage from conventional weapons that penetrate the subgrade and have an apparent crater diameter greater than or equal to 15 feet.

Minimum operating strip (MOS).

The smallest amount of area that an air base manager must repair in order to launch and recover aircraft after an attack. Selection of this MOS will depend upon mission requirements, taxi access, resources available, and estimated time to repair. The current NATO standard for an MOS is 50 feet wide by 5,000 feet long.

Nuclear, biological, chemical (NBC).

This term refers to the possible environments in which forces may have to conduct wartime missions. Nuclear weapons, biological agents, and chemical munitions are all possessed by the Threat. Friendly forces must be trained to operate in environments which feature any combination of these weapons.

Pavement types.

Air base pavements are normally constructed using Portland cement concrete (PCC), asphaltic concrete, or PCC with asphalt overlay.

Pavement upheaval.

This is the vertical displacement of the air base pavement around the edge of an explosion produced crater. The pavement upheaval is within the crater damage diameter, but is outside the apparent crater diameter. The upheaved pavement may be completely removed, partly removed, or not removed during the repair process depending upon the repair quality level.

Percent change in slope.

This parameter establishes the maximum rate of change of the repair height and is applicable to both the upheaved pavement and the repair surface. For example, if the damaged pavement is heaved 1.5 inches in 5 feet, then this represents a $(1.5 / (5 \times 12))$ 2.5 percent change in slope from the adjacent undamaged pavement. Typically, change in slope is measured with a template.

Prime BEEF.

A HQ Air Force major command (MACOM) and base-level program that organizes civil engineering forces for worldwide direct and indirect combat support roles. It assigns civilian and military personnel to both peacetime real property maintenance and wartime engineering functions.

Rapid Engineering Deployable, Heavy Operations Repair Squadrons, Engineering (RED HORSE).

RED HORSE squadrons are HQ Air Force controlled squadrons established to provide the Air Force with a highly mobile, self-sufficient, rapidly deployable, civil engineering capability required in a potential theater of operations.

Rapid runway repair (RRR).

Rapid or emergency repair of air traffic surfaces that enable aircraft to be launched and recovered within four hours following an enemy attack.

Repair diameter.

This is the maximum distance across the repair, not necessarily parallel to the MOS centerline. The repair diameter is measured from the unremoved pavement on one side of the repair to the unremoved pavement on the other side. The repair diameter represents the portion of the repair that has a different load-bearing capability than the original pavement.

Repair quality.

The maximum height permissible for an upheaved but repaired runway surface above the original surface elevation. It is a quantity determined by the Air Force BCE and can be specified as either 0, 1, 1 1/2, 3, or 4 1/2 inches above the original surface of the runway. This specification includes the FOD cover or other appropriate repair material.

Sag.

The vertical distance between the low points of a repair and an imaginary repair surface. In order to measure sag, the imaginary repair surface must be established by stretching a string across the repair so that it contacts the pavement just outside the start of the upheaval. Then, the vertical distance from the repair surface to the string must be measured. Sag will probably increase with aircraft traffic as the fill settles.

Screed beam.

A leveling device which can be set to various depths and pulled across a layer of chipped stone, select fill, and so forth, to level the surface.

Small crater.

Pavement damage from conventional weapons that penetrate/disturb the subgrade. This results in possible pavement upheaval around the crater edge and an apparent crater diameter of less than 15 feet.

Sortie.

This term refers to the combination of one takeoff and landing by one particular aircraft.

Spans or scabs.

Pavement damage that does not penetrate the pavement surface into the base course and which results in a damage area that could be up to 5 feet in diameter.

Survival recovery center (SRC).

A supplemented command post that is collocated with, or immediately adjacent to, the wing command post to ensure expeditious resumption of flying operations after attack. The Combat Support Group (CSG) commander directs operations of the SRC. The BCE is a member of the SRC staff.

Time-Phased Force and Deployment List (TPFDL).

The appendix to Annex A (Task Organization) of an operation plan which identifies the type units to be deployed, their time of deployment, and data concerning their destination.

True crater diameter

The diameter across the upheaved pavement from the start of upheaval on one side of the crater to the end of the upheaval on the far side of the crater.

Unexploded ordnance (UXO).

A term which refers to unexploded, munitions dropped by the enemy on the air base. These may be of any type, shape, or size.

War reserve materiel (WRM).

Materiel required in addition to peacetime assets to support the planned wartime activities reflected in the US Air Force War and Mobilization Plan.

REFERENCES

REQUIRED PUBLICATIONS

Required publications are sources that users must read in order to understand or to comply with this publication.

Army Regulation (AR)

415-30 Troop Construction and Engineering Support of the Air Force Overseas

Field Manuals (FMs)

90-14 Rear Battle
100-5 Operations

Technical Manuals (TMs)

5-301 Army Facilities Components System - Planning
5-302 Army Facilities Components System - Designs
5-303 Army Facilities Components System - Logistics Data and Bills of Materials
5-304 Army Facilities Components System - User Guide

RELATED PUBLICATIONS

Related publications are sources of additional information. They are not required in order to understand this publication.

Air Force Regulations (AFRs)

93-2 Contingency Response Planning
93-3 Air Force Civil Engineering Prime BEEF Program
93-9 Civil Engineering RED HORSE Squadrons

These publications are available from the Air Force Engineering and Services Center, Tyndall Air Force Base, Florida 32403-6001.

Field Manuals (FMs)

3-4 NBC Protection
3-5 NBC Decontamination

- 3-100 NBC Operations
- 5-25 Explosives and Demolitions
- 5-100 Engineer Combat operations
- 5-103 Survivability
- 5-104 General Engineering
- 5-333 Construction Management
- 5-335 Drainage
- 5-530 Materials Testing
- 5-541 Military Soils Engineering
- 5-551 Carpentry
- 5-742 Concrete and Masonry
- 21-10 Field Hygiene and Sanitation
- 100-10 Combat Service Support
- 100-16 Support Operations: Echelons Above Corps
- 101-5 Staff Organization and Operations

Technical Manuals (TMs)

- 5-200 Camouflage Materials
- 5-330 Planning and Design of Roads, Airbases, and Heliports in the Theater of Operations
- 5-337 Paving and Surfacing Operations
- 5-343 Military Petroleum Pipeline Systems
- 5-704 Construction Print Reading in the Field

PROJECTED PUBLICATIONS

Projected publications are sources of additional information that are scheduled for printing but are not yet available. When published, they will be distributed automatically via pinpoint distribution. They may not be obtained from the US Army Adjutant General Publications Center until indexed in DA Pamphlet 25-30.

Field Manual (FM)

- 5-116 Engineer Operations: Echelons Above Corps

OTHER PUBLICATIONS

Other publications are sources of information such as quoted per paraphrased portions of the text.

USAF War and Mobilization Plan (WMP-1): Volume 1, Annex S, Appendix 4 - Fire Protection. This publication is available from the Air Force Engineering and Services Center, Tyndall Air Force Base, Florida 32403-6001.

INDEX

ADR responsibilities

Air Force, 1-4, 1-5

Army, 1-4, 1-5

Air base restoration, 1-9

Assessment techniques, 5-4

Crater repair. See also spall repair

Air Force, A-1

Army, B-1

concrete cap, B-3, H-11

crushed stone, A-4

FOD covers, A-5, H-10

precast concrete slab, A-9

sand grid, B-2

stone and grout, B-4, H-11

Damage Assessment Team, 2-2

Damage Control Center, 2-2

Damage evaluation, 5-7

Deployment phase

bivouac, 1-6

mobilization, 1-6

Facility damage assessment, 5-6

FRP mats

assembly and fabrication of, D-1

Interface

Air Force, 3-1

Army, 3-1

MOS selection team, 2-2

New facilities

construction of, F-1

Operation concept, 1-1

Pavement repair

access routes, 6-1

beyond emergency, 1-8, 3-2, 6-4, H-1- H-12

emergency, 1-8, 3-2, 6-4, H-1- H-12

MOS location, 6-1

surface roughness, 6-2

UXO removal, 6-2

Postattack, 1-7

actions, 5-1

Preattack, 1-7

actions, 4-1

Prime BEEF, 1-4, 1-9, 2-1, G-3

RED HORSE, 1-4, 1-9, 2-1, G-1

Repair team configuration, H-1- H-12

Structure and utility repair, H-3, H-4

priority, 7-2

responsibility 7-1

Survival Recovery Center (SRC), 2-1

THREAT doctrine

air-delivered munitions, 1-3

missile-delivered munitions, 1-3

Special Operations Ground Forces, 1-3

UXO disposal, E-1

TC 5-340
27 DECEMBER 1988

By Order of the Secretary of the Army:

CARL E. VUONO
General, United States Army
Chief of Staff

Official:

WILLIAM J. MEEHAN II
Brigadier General United States Army
The Adjutant General

DISTRIBUTION:

Active Army, USAR, and ARNG: To be distributed in accordance with DA Form 12-11E, requirements for Hasty Revetments for Parked Aircraft (Qty rqr block no. 755).

PIN: 065108-000